

# JETON®

- 萬向曲管 & 油霧回收真空曲管
- 高壓萬向噴嘴 & 噴霧裝置

JETON R/D & MFG. INC.

宏瑀工業股份有限公司  
宏啓工業股份有限公司

No.17, Lane 100, Tsao-Tyi Road,  
Ta-Li Dist., Taichung, Taiwan.  
台中市大里區草堤路100巷17號

Tel : +886-4-24953456  
Fax : +886-4-24953399  
E-mail : info@jeton.com.tw

Qi Jin Trading Co., Ltd.

上海奇晉貿易有限公司

Tel : 186-89-222-975  
E-mail : jetoninc@163.com

[www.jeton.com.tw](http://www.jeton.com.tw)

[WWW.JETON.COM.TW](http://WWW.JETON.COM.TW)

## 關於我們

宏玥（宏啟）工業股份有限公司  
 是一家經營超過 30 年的專業塑膠射出廠，  
 專門生產工具機專用的高壓噴嘴、  
 油霧回收真空管、萬向曲管、噴霧裝置等，  
 並擁有堅強的研發團隊來滿足客戶的各種需求。  
 本公司秉持著採用高級的原料來生產商品，  
 以提供客戶最高品質的產品來達成顧客滿意度最大為原則，  
 且持續不斷的創新，  
 並根據市場的需求來研發新的商品，  
 讓客戶能有多樣化的選擇。

關於我們	01 - 02	高壓萬向噴嘴	27 - 28
萬向曲管系列介紹	03 - 04	斜噴式	29 - 31
組合長度計算方法	05	直噴式	32 - 34
總流量控制組	06	360 度斜噴式	35 - 36
油霧回收真空管系列	07 - 08	鑲入式	37 - 38
萬向曲管配件組配表	09 - 10	鑲入式斜噴	39 - 40
1/4" 系列	11 - 12	超高壓萬向噴嘴	41 - 42
3/8" 系列	13 - 14	斜噴式	41
1/2" 系列	15 - 16	直噴式	42
3/4" 系列	17	應用範例	43 - 44
萬向曲管凡而組系列	18	噴霧裝置	45 - 46
抗酸曲管系列	19		
檔板組系列	20		
磁座組系列	21		
萬向曲管系統規格圖	22 - 26		





# JETON

## 萬向曲管 & 油霧回收真空曲管

### 萬向曲管系列介紹

可任意調整長度、角度、變換口徑，專門用來輸送流體（液體、氣體）的曲管。  
可使用於金屬機械加工給水／給油、吹氣的曲管。

- ▶ 材料使用高品質的POM塑膠原料，具有抗化學性、油性、藥品性。
- ▶ 萬向曲管繞性佳，定位穩固，不會反彈。
- ▶ 彎曲後不會縮減內徑，也不會打結或疲乏。
- ▶ 與切削刀具碰撞，萬向曲管不會破壞切削刀具。
- ▶ 萬向曲管不會導電，適合用於EDM（放電加工機）。
- ▶ 有五種內徑尺寸：1/4", 3/8", 1/2", 3/4", 2 1/2"。
- ▶ 萬向曲管適用於低壓力的流體輸送。

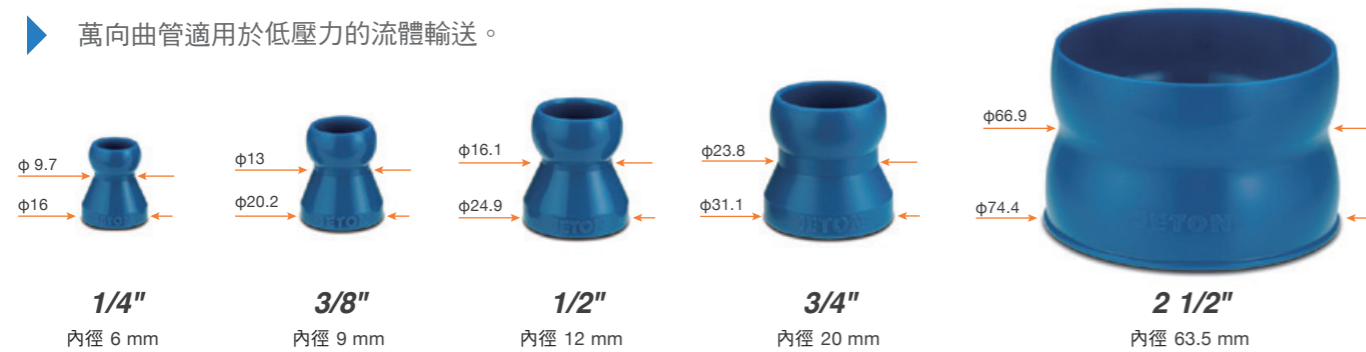

### 萬向曲管之最大外徑與最小外徑尺寸對照表圖

1/4" 系列	2.0~3.0 kg/cm <sup>2</sup>	900 公升 / 小時
3/8" 系列	2.0~3.0 kg/cm <sup>2</sup>	1500 公升 / 小時
1/2" 系列	1.4~2.0 kg/cm <sup>2</sup>	1700 公升 / 小時
3/4" 系列	0.7~1.4 kg/cm <sup>2</sup>	1900 公升 / 小時

### 溫度說明

最高使用溫度：

65° C

熔點：

165° C

### 建議使用

使用萬向曲管時，會因使用情況的不同，而影響曲管的最大壓力，建議任何時候做測試。

### 萬向曲管包裝

萬向曲管提供吊卡包裝、袋裝及捲裝，可依客戶的需求做不同之包裝。



### 適用物品表

一般型萬向曲管以高品質POM塑膠原料製造，色澤採用深藍色及橘色

#### 適用

- 乙醇
- 丙酮
- 清潔劑
- 汽油
- 潤滑油
- 酒精
- 礦物油
- 氫氧化鈉
- 農藥
- 煞車油

#### 不適用

- 酸
- 強鹼
- 氨類過氧化物
- 次氯酸
- 次氯酸鈉



## 萬向曲管組合長度計算方法

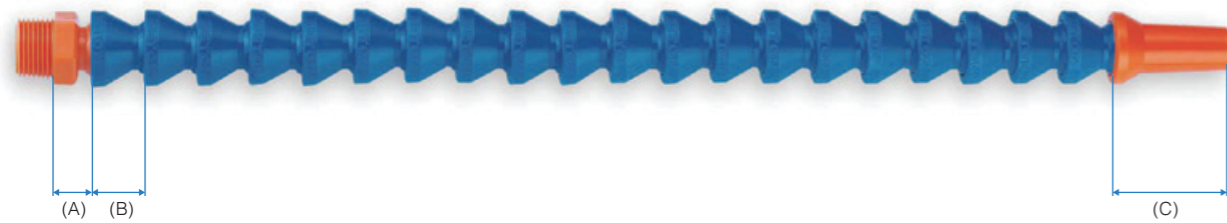

接頭尺寸 (A) + 曲管本體尺寸 (B x 顆粒數) + 噴嘴尺寸 (C) = 全長

1/4" 10.2 + 14.5 mm x 顆粒數 + 35.2 mm = 全長

3/8" 12.7 + 17.4 mm x 顆粒數 + 39.2 mm = 全長

1/2" 14.2 + 20.9 mm x 顆粒數 + 37.8 mm = 全長

3/4" 14.2 + 23.7 mm x 顆粒數 + 43.0 mm = 全長

## 萬向曲管的組裝

使用專用的曲管組裝鉗即可簡單的拆裝曲管。



## 總流量控制組

能配合各種機械需求整合配置水流，在安裝上更為簡單容易，並能增加整台機械的美觀，操控水流更為方便。

### JTM-01 控制組

- 總流量控制組座 1 組
- 1/4" 萬向曲管凡而組 1 支
- 3/8" 萬向曲管凡而組 3 支

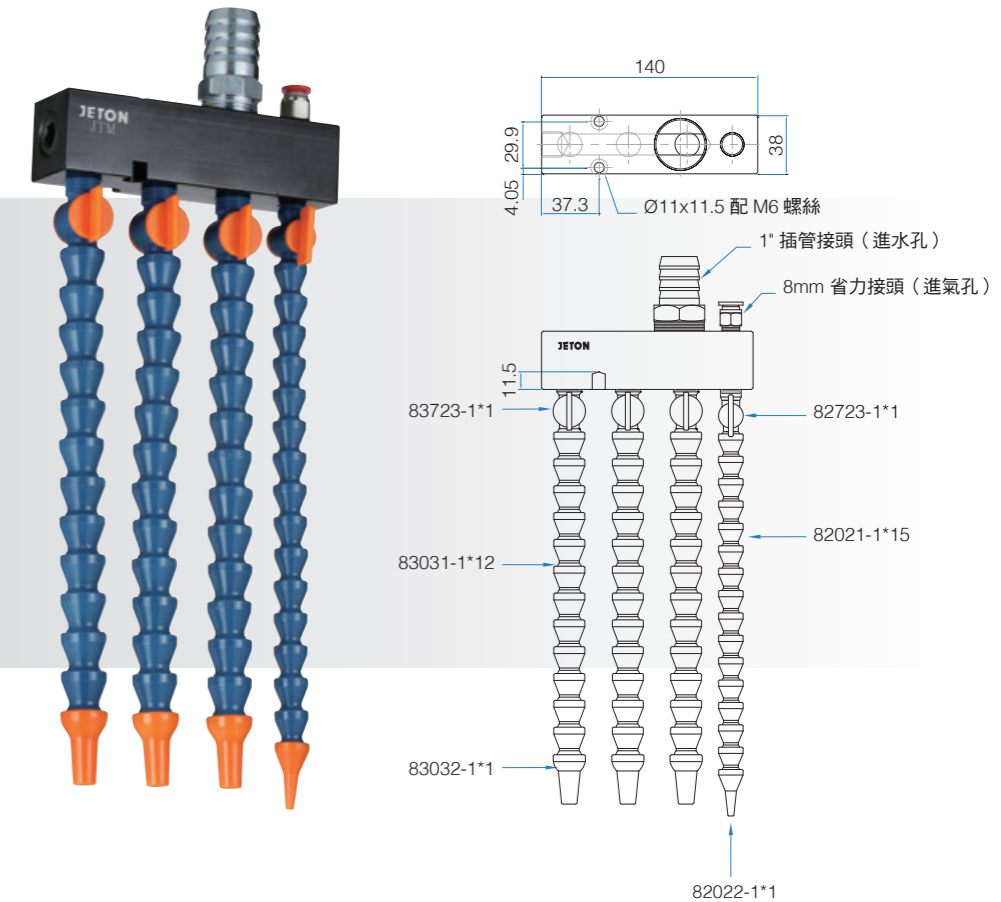

### JTM-02 控制組

- 總流量控制組座 1 組
- 1/4" 萬向曲管凡而組 1 支
- 高壓式萬向噴嘴 3 顆
- 銅質開關 3 顆

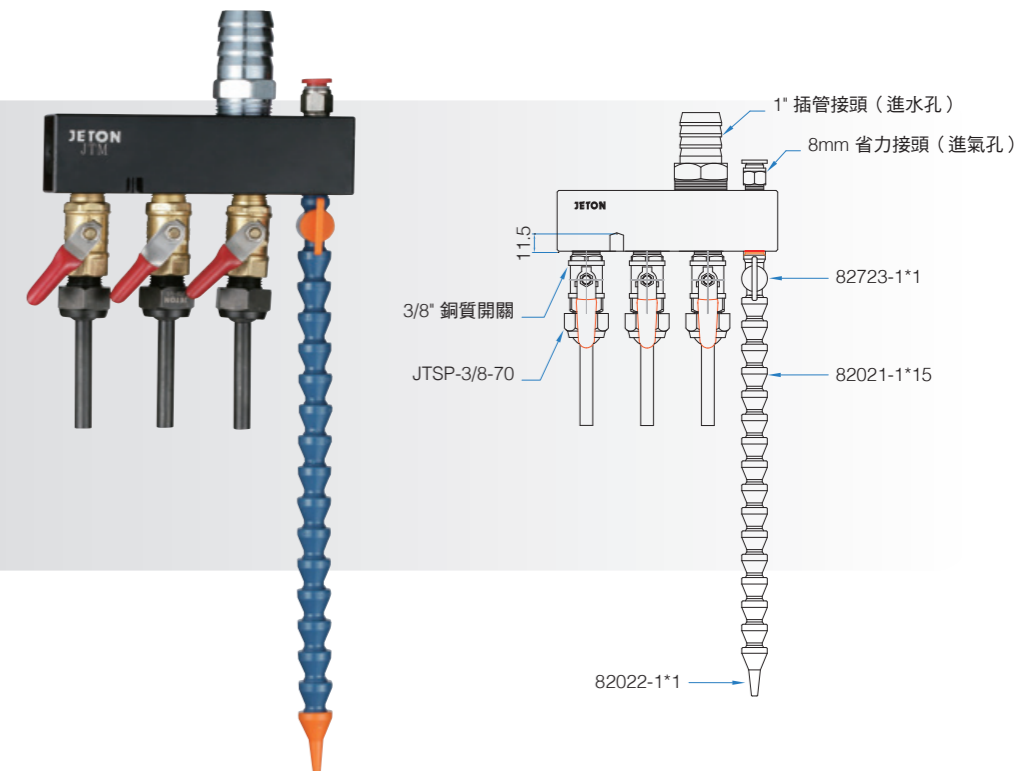

## 油霧回收真空曲管特色

2 1/2"的油霧回收真空曲管是專門設計在油霧回收系統裡，用來吸取灰塵、煙霧和微粒。放在工作範圍之內方便調整角度。可隨著工作需求來更改長度。並有多樣的接頭與噴嘴，可提供選擇其中最適合的搭配。  
2 1/2"的油霧回收真空曲管可與美規3"PVC排水管或3"金屬管及可攜式吸塵器連接。

- ▶ 可旋轉360度，角度調整容易。可固定在理想的工作位置。
- ▶ 耐用和抗擠壓，不易被磨損。
- ▶ 用優質的塑膠材質製造，可抗大部份化學物品。
- ▶ 容易彎曲，彎曲後不會縮減內徑。彎曲半徑大約145mm。

### 溫度說明

最高使用溫度：

65° C

熔點：

165° C

### 警告

油霧回收真空曲管採用塑膠材質製造。這種原料是易燃的，須遠離火源，否則可能會引起火災。



## 油霧回收真空曲管系列 (2 1/2" 內徑)

產品	品號	產品規格	產品	品號	產品規格	
	<b>89091</b> <b>89191</b> <b>89291</b>	真空曲管組 9個/組 18個/組 180個/組	 (連接金屬管專用)	<b>89097</b> <b>89197</b>	3" 金屬專用接頭 1個 10個	
	<b>89094</b> <b>89194</b>	4.5" 圓形嘴 1個 10個		<b>89099</b> <b>89199</b>	真空曲管接頭 1個 10個	
	<b>89092</b> <b>89192</b>	6" x 3.5" 矩形嘴 1個 10個		<b>89021</b> <b>89121</b>	4" 轉 2.5" 真空曲管接頭 1個 10個	
	<b>89093</b> <b>89193</b>	錐形嘴 1個 10個		<b>89038</b>	4" 轉 2.5" Y形接頭 1個	
	<b>89722</b> <b>89742</b>	2.5" 滑動凡而 1個 10個		<b>89101</b>	2.5" 固定座 1個	
	<b>89096</b> <b>89196</b>	真空曲管接頭，附掛耳 1個 10個		<b>89102</b>	4" 轉 2.5" 固定座 1個	
	<b>89095</b> <b>89195</b>	真空曲管接頭 1個 10個		<b>89103</b>	4" 轉 2.5" Y形接頭固定座 1個	
	<b>89098</b> <b>89198</b>	3" PVC 專用接頭 1個 10個	<b>所有產品皆有黑色選項</b>			
(連接美規PVC管專用)						

如何訂購黑色版本的产品?  
在产品型号尾端加入-B，例如: 89094-B

1/4" 系列

公母牙接頭	多形接頭	噴嘴
<p><b>82025</b> 1/8" PT公牙接頭</p> <p><b>82026</b> 1/4" PT公牙接頭</p> <p><b>82013</b> 5/8" UNF母牙接頭</p> <p><b>82014</b> 7/16" UNF母牙接頭</p> <p><b>82723</b> 1/4" 公牙凡而</p> <p><b>82724</b> 1/4" 母牙凡而</p>	<p><b>82028</b> 1/4" Y型接頭</p> <p><b>82011</b> 1/4" 雙向接頭</p> <p><b>82220</b> 1/4" 加長型曲管組</p> <p><b>62420</b> 1/4" L形接頭</p> <p><b>62422</b> 1/4" 環狀噴嘴</p> <p><b>62424</b> 1/4" 末端帽蓋</p> <p><b>62426</b> 1/4" T形接頭</p> <p><b>82722</b> 1/4" 連接凡而</p> <p><b>82725</b> 1/4" 止逆閥</p>	<p><b>82029</b> 1/4" PT公牙接頭</p> <p><b>82012</b> 1/4" 管節, 1/8" NPT母牙接頭</p> <p><b>82052</b> 1/4" PT母牙接頭</p> <p><b>82062</b> 1/4" NPTF母牙接頭</p> <p><b>82054</b> 1/4" 直噴式噴嘴</p> <p><b>82055</b> 1/4" 直噴式噴嘴</p> <p><b>82056</b> 1/4" 直噴式多孔噴嘴</p> <p><b>82057</b> 1/4" 直噴式多孔噴嘴</p> <p><b>82053</b> 1" 直流式噴嘴</p> <p><b>82227</b> 2-1/2" 扇形多孔噴嘴</p> <p><b>82022</b> 1/16" 圓形噴嘴</p> <p><b>82023</b> 1/8" 圓形噴嘴</p> <p><b>82024</b> 1/4" 圓形噴嘴</p> <p><b>82223</b> 1/16" 90°噴嘴</p> <p><b>82224</b> 1/8" 90°噴嘴</p> <p><b>82225</b> 1/4" 90°噴嘴</p> <p><b>82226</b> 1/4" 90°多孔噴嘴</p> <p><b>82017</b> 3/8" 扇形噴嘴</p> <p><b>82027</b> 1" 扇形噴嘴</p> <p><b>82228</b> 1/4" 扇形多孔噴嘴</p> <p><b>82229</b> 1/4" 扇形多孔噴嘴</p>

1/2" 系列

公母牙接頭	多形接頭	噴嘴
<p><b>84045</b> 1/2" PT公牙接頭</p> <p><b>84046</b> 3/8" PT公牙接頭</p> <p><b>84013</b> 5/8" UNF母牙</p> <p><b>84723</b> 1/2" PT公牙凡而</p> <p><b>84724</b> 1/2" PT母牙凡而</p>	<p><b>84011</b> 1/2" 雙向接頭</p> <p><b>84048</b> 1/2" Y形接頭</p> <p><b>84049</b> 1/2" 轉1/4" Y形接頭</p> <p><b>84651</b> 1/2" 轉1/4" 接頭</p> <p><b>84440</b> 1/2" 加長型曲管組</p> <p><b>64620</b> 1/2" L形接頭</p> <p><b>64622</b> 1/2" 環狀噴嘴</p> <p><b>64626</b> 1/2" T形接頭</p> <p><b>84722</b> 1/2" 連接凡而</p> <p><b>84725</b> 1/2" 止逆閥</p>	<p><b>84047</b> 1-1/4" 扇形噴嘴</p> <p><b>84050</b> 1-3/4" 扇形噴嘴</p> <p><b>84052</b> 2-1/2" 扇形噴嘴</p> <p><b>84054</b> 1/2" 直噴式噴嘴</p> <p><b>84055</b> 1/2" 直噴式噴嘴</p> <p><b>84056</b> 1/2" 直噴式多孔噴嘴</p> <p><b>84057</b> 1/2" 直噴式多孔噴嘴</p> <p><b>84058</b> 1-1/4" 直流式噴嘴</p> <p><b>84059</b> 1-5/8" 直流式噴嘴</p> <p><b>84042</b> 3/8" 圓形噴嘴</p> <p><b>84043</b> 1/2" 圓形噴嘴</p> <p><b>84044</b> 1/4" 圓形噴嘴</p> <p><b>84443</b> 1/4" 90°噴嘴</p> <p><b>84444</b> 3/8" 90°噴嘴</p> <p><b>84445</b> 1/2" 90°噴嘴</p> <p><b>84446</b> 1/2" 90°多孔噴嘴</p> <p><b>84447</b> 2-1/2" 扇形多孔噴嘴</p>

3/8" 系列

公母牙接頭	多形接頭	噴嘴
<p><b>83035</b> 3/8" PT公牙接頭</p> <p><b>83036</b> 1/2" PT公牙接頭</p> <p><b>83026</b> 1/4" PT公牙接頭</p> <p><b>83723</b> 3/8" PT公牙凡而</p> <p><b>83724</b> 3/8" PT母牙凡而</p>	<p><b>83038</b> 3/8" Y形接頭</p> <p><b>83011</b> 3/8" 雙向接頭</p> <p><b>83651</b> 3/8" 轉1/4" 接頭</p> <p><b>83722</b> 3/8" 連接凡而</p> <p><b>83725</b> 3/8" 止逆閥</p> <p><b>63620</b> 3/8" L形接頭</p>	<p><b>83032</b> 1/4" 圓形噴嘴</p> <p><b>83033</b> 3/8" 圓形噴嘴</p> <p><b>83034</b> 1/2" 圓形噴嘴</p> <p><b>83037</b> 1-1/4" 扇形噴嘴</p>

3/4" 系列

公母牙接頭	多形接頭	噴嘴
<p><b>86064</b> 3/4" PT公牙接頭</p> <p><b>86723</b> 3/4" PT公牙凡而</p> <p><b>86724</b> 3/4" PT母牙凡而</p>	<p><b>86068</b> 3/4" Y形接頭</p> <p><b>86069</b> 3/4" 轉1/2" Y形接頭</p> <p><b>86051</b> 3/4" 轉1/2" 接頭</p> <p><b>86011</b> 3/4" 雙向接頭</p> <p><b>66620</b> 3/4" L形接頭</p> <p><b>86722</b> 3/4" 連接凡而</p>	<p><b>86063</b> 5/8" 圓形噴嘴</p> <p><b>86062</b> 3/4" 圓形噴嘴</p> <p><b>86067</b> 3" 扇形噴嘴</p>

# 1/4" 系列 (1/4" 內徑)

產品	品號	產品規格	產品	品號	產品規格	產品	品號	產品規格	產品	品號	產品規格	產品	品號	產品規格
	82020	1/4"曲管組 15cm 曲管 2條 1/16", 1/8", 1/4" 圓形噴嘴各1個 1/8" & 1/4" PT 公牙接頭各1個		82326	1/4" 90°噴嘴組 1/16", 1/8", 1/4" 90°圓形噴嘴與 1/4" 90°多孔噴嘴各1個		82027 82047	1" 扇形噴嘴 2個 20個		82029 82039	1/4" PT公牙接頭 4個 50個		62426 62436	1/4" T形接頭 2個 20個
	82020A	1/4"曲管組 15cm 曲管 2條 1/16", 1/8", 1/4" 圓形噴嘴各1個 1/8" & 1/4" NPT 公牙接頭各1個		82022 82042	1/16" 圓形噴嘴 4個 50個 (孔徑:1.5mm)		82055 82075	1/4" 直噴式噴嘴 2個 20個 (1.5mm)		82028 82038	1/4" Y形接頭 2個 20個		62422 62442	1/4" 環狀噴嘴 4個 20個
	82220	1/4" 加長型曲管組 加長型曲管 4個 管束 4個		82023 82043	1/8" 圓形噴嘴 4個 50個 (孔徑:3.1mm)		82056 82076	1/4" 直噴式多孔噴嘴 2個 20個 (7孔, 孔徑:1mm)		82011 82031	1/4" 雙向接頭 4個 20個		62424 62444	1/4" 末端帽蓋 4個 20個
	82221 82241	1/4" 加長型曲管 4個 20個		82024 82044	1/4" 圓形噴嘴 4個 50個 (孔徑:6.3mm)		82057 82077	1/4" 直噴式多孔噴嘴 2個 20個 (5孔, 孔徑:1.5mm)		82052 82072	1/4" PT母牙接頭 4個 50個		82228 82248	1/4" 扇形多孔噴嘴 2個 20個 (16孔, 孔徑:1.0mm)
	82021	1/4" 曲管 15cm 曲管 2條		82223 82243	1/16" 90°噴嘴 4個 20個 (孔徑:1.8mm)		82053 82073	1" 直流式噴嘴 2個 20個		82052F 82072F	1/4" PF母牙接頭 4個 50個		82229 82249	1/4" 扇形多孔噴嘴 2個 20個 (16孔, 孔徑:1.5mm)
	82051 82071	1/4" 曲管 1524cm 曲管 1捲 2500cm 曲管 1捲		82224 82244	1/8" 90°噴嘴 4個 20個 (孔徑:3mm)		82025 82035	1/8" PT公牙接頭 4個 50個		82062 82082	1/4" NPTF母牙接頭 4個 50個		82721A 82731A	1/4" NPT公牙插管凡而 2個 10個
	62423	1/4" 環狀噴嘴組 環狀噴嘴 15個 末端帽蓋 1個		82225 82245	1/4" 90°噴嘴 4個 20個 (孔徑:6.1mm)		82025A 82035A	1/8" NPT公牙接頭 4個 50個		82013 82033	5/8" UNF母牙接頭 4個 20個		82722 82732	1/4" 連接凡而 2個 10個
	82221 82241	1/4" 加長型曲管 4個 20個		82226 82246	1/4" 90°多孔噴嘴 2個 20個 (6孔, 孔徑:2.3mm)		82026 82036	1/4" PT公牙接頭 4個 50個		82014 82034	7/16" UNF母牙接頭 4個 20個		82723 82733	1/4" PT公牙凡而 2個 10個
	82222 82242	1/4"管束 4個 20個		82017 82037	3/8" 扇形噴嘴 2個 20個		82026A 82036A	1/4" NPT公牙接頭 4個 50個		62420 62430	1/4" L形接頭 2個 20個	<p><b>所有產品皆有黑色選項</b></p> <p>如何訂購黑色版本的產品? 在產品型號尾端加入-B 例如: 89094-B</p>		

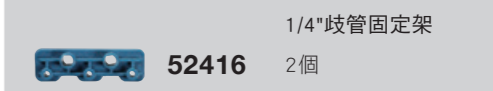

# 3/8" 系列 (3/8" 內徑)

產品	品號	產品規格
		3/8" 曲管組
		14.5cm 曲管 2條
	<b>83030</b>	3/8" 圓形噴嘴 1個
		3/8" PT公牙接頭 1個
		3/8" 曲管組
		14.5cm 曲管 2條
	<b>83030A</b>	3/8" 圓形噴嘴 1個
		3/8" NPT公牙接頭 1個
		3/8" 曲管組
		14.5cm 曲管 2條
	<b>83430</b>	1/4", 3/8", 1/2" 圓形噴嘴各1個
		3/8" 和 1/2" PT 公牙接頭各1個
		3/8" 曲管組
		14.5cm 曲管 2條
	<b>83430A</b>	1/4", 3/8", 1/2" 圓形噴嘴各1個
		3/8" 和 1/2" NPT 公牙接頭各1個
	<b>83031</b>	3/8" 曲管組 14.5cm 曲管 2條 (每條8顆)
	<b>83051</b>	3/8" 曲管組 762cm 曲管 1捲
	<b>83091</b>	1524cm 曲管 1捲
	<b>83032</b>	1/4" 圓形噴嘴 4個
	<b>83052</b>	50個 (孔徑:6.3mm)

產品	品號	產品規格
	<b>83033</b>	3/8" 圓形噴嘴 4個
	<b>83053</b>	50個 (孔徑:9.6mm)
	<b>83034</b>	1/2" 圓形噴嘴 4個
	<b>83054</b>	50個 (孔徑:12mm)
	<b>83026</b>	1/4" PT公牙接頭 4個
	<b>83046</b>	50個
	<b>83035</b>	3/8" PT公牙接頭 4個
	<b>83055</b>	50個
	<b>83035A</b>	3/8" NPT公牙接頭 4個
	<b>83055A</b>	50個
	<b>83036</b>	1/2" PT公牙接頭 4個
	<b>83056</b>	50個
	<b>83036A</b>	1/2" NPT公牙接頭 4個
	<b>83056A</b>	50個
	<b>83037</b>	1 1/4" 扇形噴嘴 2個
	<b>83057</b>	20個
	<b>83038</b>	3/8" Y形接頭 2個
	<b>83058</b>	20個

產品	品號	產品規格
	<b>83011</b>	3/8" 雙向接頭 4個
	<b>83041</b>	20個
	<b>83725</b>	3/8" 止逆閥 2個
	<b>83745</b>	10個
	<b>83651</b>	3/8" 曲管轉 1/4" 曲管接頭 2個
	<b>83851</b>	20個
	<b>63620</b>	3/8" L形接頭 2個
	<b>63640</b>	20個
	<b>83722</b>	3/8" 連接凡而 2個
	<b>83742</b>	10個
	<b>83723</b>	3/8" PT公牙凡而 2個
	<b>83743</b>	10個
	<b>83723A</b>	3/8" NPT公牙凡而 2個
	<b>83743A</b>	10個
	<b>83724</b>	3/8" PT母牙凡而 2個
	<b>83744</b>	10個
	<b>83724A</b>	3/8" NPT母牙凡而 2個
	<b>83744A</b>	10個
	<b>26176</b>	鋁製3/8"曲管組裝鉗 1支

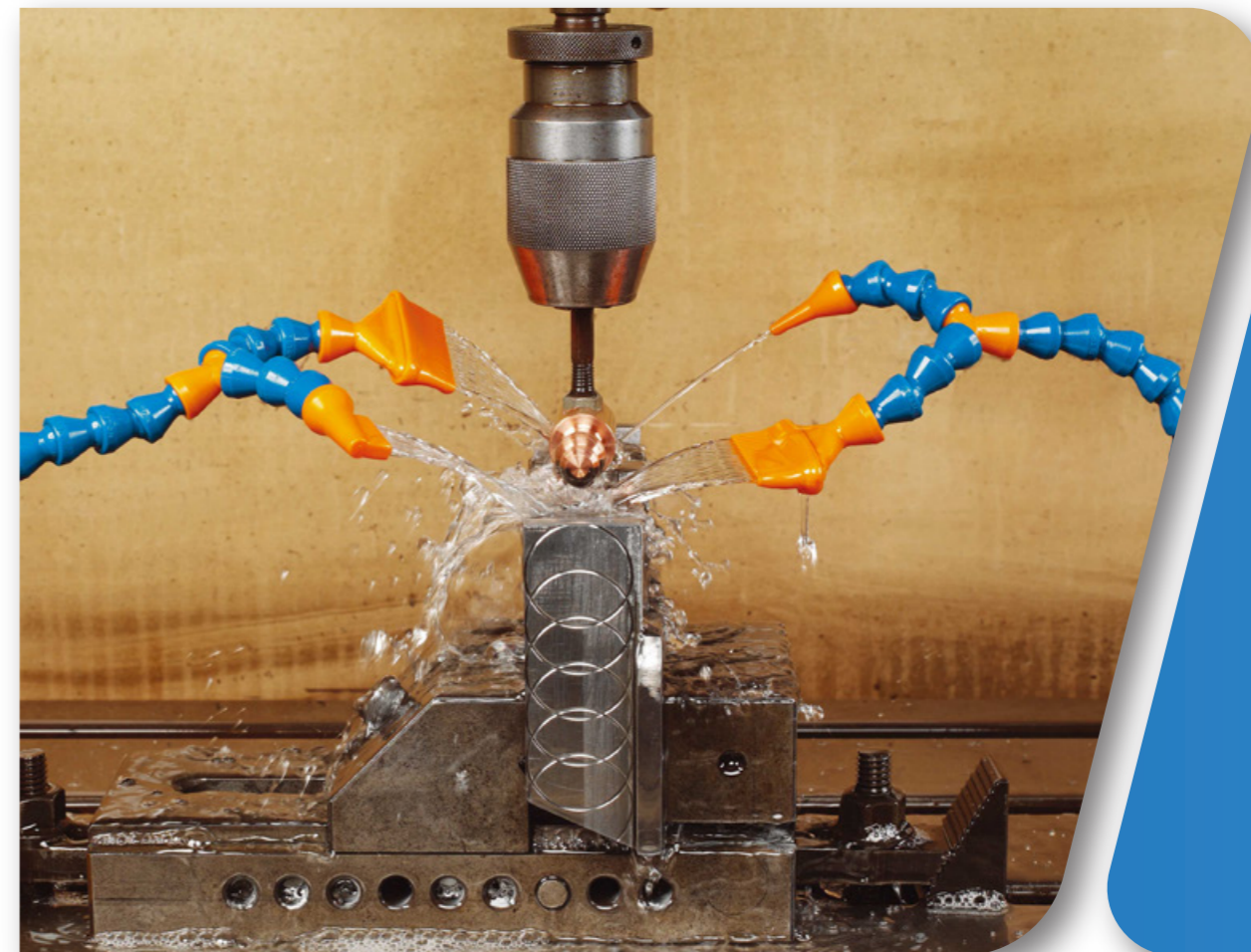

所有產品皆有黑色選項



如何訂購黑色版本的產品?

在產品型號尾端加入-B 例如: 89094-B

產品	品號	產品規格	產品	品號	產品規格	產品	品號	產品規格	產品	品號	產品規格	產品	品號	產品規格				
	<b>84040</b>	1/2" 曲管組		<b>84346</b>	1/2 90° 噴嘴組		<b>84054</b>	2個		<b>84447</b>	2個		<b>64620</b>	2個				
		13.5cm 曲管 2條						1/4", 3/8", 1/2" 90° 圓形噴嘴各1個						20個		20個		20個
		1/4", 3/8", 1/2" 圓形噴嘴各1個						1/2" 直噴式噴嘴 (2mm)						20個		20個		20個
	<b>84040A</b>	1/2" 曲管組		<b>84044</b>	1/4" 圓形噴嘴		<b>84055</b>	2個		<b>84046</b>	4個		<b>64626</b>	2個				
		13.5cm 曲管 2條						1/2" 90° 圓形噴嘴與 1/2" 90° 多孔噴嘴各1個						20個		20個		20個
		1/4", 3/8", 1/2" 圓形噴嘴各1個						1/2" 直噴式噴嘴 (3.2mm)						20個		50個		20個
		3/8"和1/2" NPT 公牙接頭各1個																
	<b>84440</b>	1/2" 加長型曲管組		<b>84064</b>	1/4" 圓形噴嘴		<b>84056</b>	2個		<b>84046A</b>	4個		<b>64622</b>	4個				
		加長型曲管 4個						3/8" 圓形噴嘴						20個		50個		20個
		管束 4個																
	<b>84041</b>	1/2" 曲管		<b>84043</b>	1/2" 圓形噴嘴		<b>84058</b>	2個		<b>84045</b>	4個		<b>64624</b>	4個				
		13.5cm 曲管 2條 (每條6顆)						1/2" 圓形噴嘴 (孔徑:12.6mm)						20個		20個		50個
	<b>84081</b>	1/2" 曲管		<b>84443</b>	3/8" 圓形噴嘴		<b>84059</b>	2個		<b>84048</b>	2個		<b>84722</b>	2個				
		1524cm 曲管 1捲						1/2" 圓形噴嘴 (孔徑:12.6mm)						20個		20個		20個
	<b>84091</b>	2500cm 曲管 1捲																
	<b>64643</b>	1/2" 環狀噴嘴組		<b>84463</b>	1/4" 90° 噴嘴		<b>84079</b>	20個		<b>84049</b>	2個		<b>84723</b>	2個				
		環狀噴嘴 15個						3/8" 90° 噴嘴						20個		20個		20個
		末端帽蓋 1個																
	<b>84441</b>	1/2" 加長型曲管		<b>84464</b>	1/2" 90° 噴嘴		<b>84070</b>	20個		<b>84651</b>	2個		<b>84724</b>	2個				
		4個						1/2" 90° 噴嘴 (孔徑:12.6mm)						20個		20個		20個
	<b>84461</b>	20個																
	<b>84442</b>	1/2" 管束		<b>84466</b>	2 1/2" 扇形噴嘴		<b>84072</b>	2個		<b>84011</b>	4個		<b>84724A</b>	2個				
		4個						1/2" 90° 多孔噴嘴 (8孔, 孔徑:4.2mm)						20個		20個		20個
	<b>84462</b>	20個																

所有產品皆有黑色選項



如何訂購黑色版本的產品?  
在產品型號尾端加入-B 例如: 89094-B



### 3/4" 系列 (3/4" 內徑)

產品	品號	產品規格
		3/4" 曲管組 15cm 曲管 2條
	<b>86060</b>	5/8" 與 3/4" 圓嘴 各1個 3/4" PT 公牙接頭 1個
		3/4" 曲管組 15cm 曲管 2條
	<b>86060A</b>	5/8" 與 3/4" 圓嘴 各1個 3/4" NPT 公牙接頭 1個
		3/4" 曲管曲管組 15 cm 曲管 2條 (每條6顆)
	<b>86061</b>	
		3/4" 曲管組 1524 cm 曲管 1捲 2500 cm 曲管 1捲
	<b>86081</b> <b>86091</b>	
	<b>86063</b> <b>86073</b>	5/8" 圓形噴嘴 4個 50個 (孔徑:16mm)
	<b>86062</b> <b>86072</b>	3/4" 圓形噴嘴 4個 50個 (孔徑:19.2mm)
	<b>86064</b> <b>86074</b>	3/4" PT 公牙接頭 4個 50個

產品	品號	產品規格
	<b>86064A</b> <b>86074A</b>	3/4" NPT公牙接頭 4個 50個
	<b>86021</b>	3/4" 固定接頭 2個
	<b>86022</b>	3/4" 磁座 1個
	<b>86023</b>	擋板連接接頭 2個
	<b>86067</b> <b>86077</b>	3" 扇形噴嘴 2個 20個
	<b>86068</b> <b>86078</b>	3/4" Y形接頭 2個 20個
	<b>86069</b> <b>86079</b>	3/4" 曲管轉1/2" 曲管Y形接頭 2個 20個
	<b>86051</b> <b>86071</b>	3/4" 曲管轉1/2" 曲管接頭 2個 20個

產品	品號	產品規格
	<b>86011</b> <b>86031</b>	3/4" 轉向接頭 4個 20個
	<b>66620</b> <b>66640</b>	3/4" L形接頭 2個 20個
	<b>86722</b> <b>86742</b>	3/4" 連接凡而 2個 10個
	<b>86723</b> <b>86743</b>	3/4" PT公牙凡而 2個 10個
	<b>86723A</b> <b>86743A</b>	3/4" NPT公牙凡而 2個 10個
	<b>86724</b> <b>86744</b>	3/4" PT母牙凡而 2個 10個
	<b>86724A</b> <b>86744A</b>	3/4" NPT母牙凡而 2個 10個
	<b>26177</b>	鋁製3/4"曲管組裝鉗 1支

所有產品皆有黑色選項



如何訂購黑色版本的產品?  
在產品型號尾端加入-B 例如: 89094-B

### 萬向曲管凡而組

#### 1/4"

62720 / 62720A 36cm 曲管組	
1/4" PT 公牙凡而 (62720)	1 顆
1/4" NPT 公牙凡而 (62720A)	1 顆
20 顆 1/4" 曲管	1 條
1/4" 圓嘴	1 顆

62721 / 62721A 36cm 曲管組	
1/4" PT 母牙凡而 (62721)	1 顆
1/4" NPT 母牙凡而 (62721A)	1 顆
20 顆 1/4" 曲管	1 條
1/4" 圓嘴	1 顆

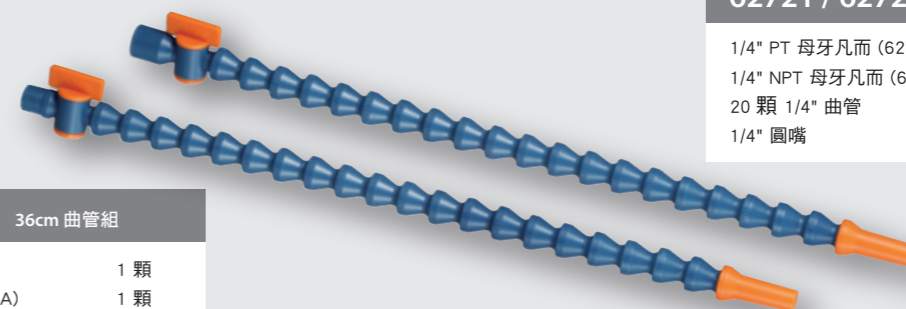

#### 3/8"

63720 / 63720A 36cm 曲管組	
3/8" PT 公牙凡而 (63720)	1 顆
3/8" NPT 公牙凡而 (63720A)	1 顆
16 顆 3/8" 曲管	1 條
3/8" 圓嘴	1 顆

63721 / 63721A 36cm 曲管組	
3/8" PT 母牙凡而 (63721)	1 顆
3/8" NPT 母牙凡而 (63721A)	1 顆
16 顆 3/8" 曲管	1 條
3/8" 圓嘴	1 顆

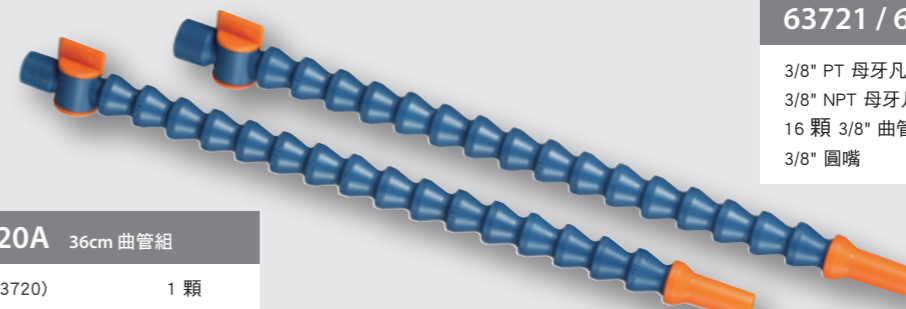

#### 1/2"

64720 / 64720A 35cm 曲管組	
1/2" PT 公牙凡而 (64720)	1 顆
1/2" NPT 公牙凡而 (64720A)	1 顆
12 顆 1/2" 曲管	1 條
1/2" 圓嘴	1 顆

64721 / 64721A 35cm 曲管組	
1/2" PT 母牙凡而 (64721)	1 顆
1/2" NPT 母牙凡而 (64721A)	1 顆
12 顆 1/2" 曲管	1 條
1/2" 圓嘴	1 顆

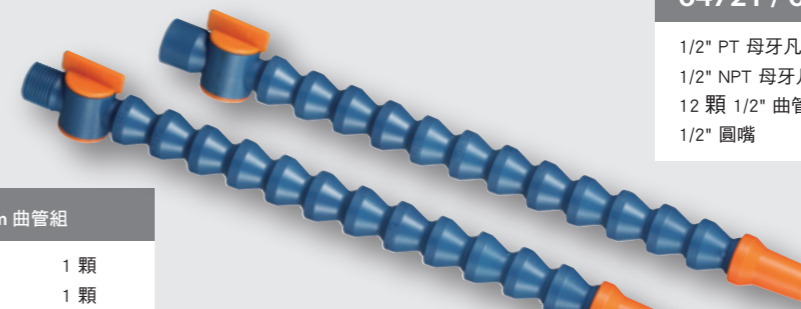

#### 3/4"

66720 / 66720A 40cm 曲管組	
3/4" PT 公牙凡而 (66720)	1 顆
3/4" NPT 公牙凡而 (66720A)	1 顆
12 顆 3/4" 曲管	1 條
3/4" 圓嘴	1 顆

66721 / 66721A 40cm 曲管組	
3/4" PT 母牙凡而 (66721)	1 顆
3/4" NPT 母牙凡而 (66721A)	1 顆
12 顆 3/4" 曲管	1 條
3/4" 圓嘴	1 顆

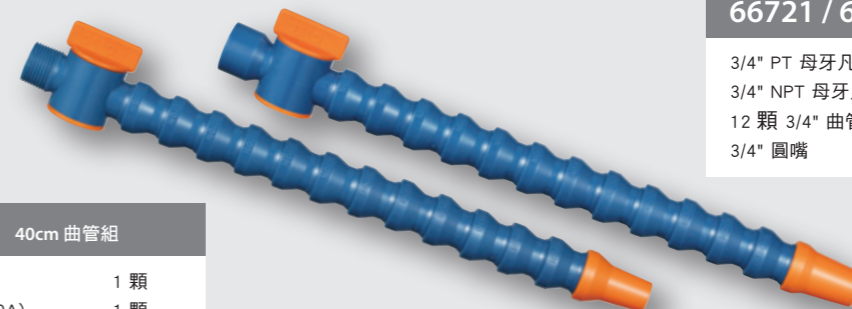

抗酸萬向曲管以聚酯塑膠製造，色澤採用灰色

## 1/4"

品號	產品規格	
<b>1/4" 抗酸曲管</b>		
52021	14 cm	2 條
52051	1524 cm	1 捲
52071	2500 cm	1 捲
<b>1/16" 抗酸圓形噴嘴</b>		
52022	4 個	
52042	50 個	
<b>1/8" 抗酸圓形噴嘴</b>		
52023	4 個	
52043	50 個	
<b>1/4" 抗酸圓形噴嘴</b>		
52024	4 個	
52044	50 個	
<b>3/8" 抗酸扇形噴嘴</b>		
52017	2 個	
52037	20 個	
<b>1" 抗酸扇形噴嘴</b>		
52027	2 個	
52047	20 個	
<b>1/8" PT 抗酸接頭</b>		
52025	4 個	
52035	50 個	
<b>1/8" NPT 抗酸接頭</b>		
52025A	4 個	
52035A	50 個	
<b>1/4" PT 抗酸接頭</b>		
52026	4 個	
52036	50 個	
<b>1/4" NPT 抗酸接頭</b>		
52026A	4 個	
52036A	50 個	
<b>1/4" PT 抗酸接頭</b>		
52029	4 個	
52039	50 個	
<b>1/4" 抗酸Y形接頭</b>		
52028	4 個	
52038	50 個	
<b>1/4" 抗酸雙向接頭</b>		
52011	4 個	
52031	20 個	
<b>1/4" 抗酸L形接頭</b>		
52420	4 個	
52430	20 個	
<b>1/4" 抗酸T形接頭</b>		
52426	4 個	
52436	20 個	

## 3/8"

品號	產品規格	
<b>3/8" 抗酸曲管</b>		
53031	14.5 cm	2 條
53051	762 cm	1 捲
53091	1524 cm	1 捲
<b>1/4" 抗酸圓形噴嘴</b>		
53032	4 個	
53052	50 個	
<b>3/8" 抗酸圓形噴嘴</b>		
53033	4 個	
53053	50 個	
<b>1/2" 抗酸圓形噴嘴</b>		
53034	4 個	
53054	50 個	
<b>1/4" PT 抗酸接頭</b>		
53026	2 個	
53046	20 個	
<b>3/8" PT 抗酸接頭</b>		
53035	2 個	
53055	20 個	
<b>3/8" NPT 抗酸接頭</b>		
53035A	4 個	
53055A	50 個	
<b>1/2" PT 抗酸接頭</b>		
53036	4 個	
53056	50 個	
<b>1/2" NPT 抗酸接頭</b>		
53036A	4 個	
53056A	50 個	
<b>1-1/4" 抗酸扇形噴嘴</b>		
53037	2 個	
53057	20 個	

### 適用物品表

#### 適用

乙醇  
酸 (加熱65°C以下)  
汽油  
潤滑油  
碳氫化合物  
礦物油  
食鹽溶劑

#### 不適用

水 (加熱65°C以上)  
酸 (加熱65°C以上)  
丙酮  
甲苯  
氯化溶劑  
醋酸乙酯  
強鹼

## 1/2"

品號	產品規格	
<b>1/2" 抗酸曲管</b>		
54041	14 cm	2 條
54081	1524 cm	1 捲
54091	2500 cm	1 捲
<b>1/4" 抗酸圓形噴嘴</b>		
54044	4 個	
54064	50 個	
<b>3/8" 抗酸圓形噴嘴</b>		
54042	4 個	
54062	50 個	
<b>1/2" 抗酸圓形噴嘴</b>		
54043	4 個	
54063	50 個	
<b>1-1/4" 抗酸扇形噴嘴</b>		
54047	2 個	
54067	20 個	
<b>1-3/4" 抗酸扇形噴嘴</b>		
54050	2 個	
54070	20 個	
<b>2-1/2" 抗酸扇形噴嘴</b>		
54052	2 個	
54072	20 個	
<b>3/8" PT 抗酸接頭</b>		
54046	4 個	
54066	50 個	
<b>3/8" NPT 抗酸接頭</b>		
54046A	4 個	
54066A	50 個	
<b>1/2" PT 抗酸接頭</b>		
54045	4 個	
54065	50 個	
<b>1/2" NPT 抗酸接頭</b>		
54045A	4 個	
54065A	50 個	
<b>1/2" 抗酸Y形接頭</b>		
54048	2 個	
54068	20 個	
<b>1/2" 轉 1/4" 抗酸Y形接頭</b>		
54049	2 個	
54069	20 個	
<b>1/2" 轉 1/4" 抗酸接頭</b>		
54651	2 個	
54851	20 個	
<b>1/2" 抗酸雙向接頭</b>		
54011	4 個	
54031	20 個	
<b>1/2" 抗酸L形接頭</b>		
54620	2 個	
54640	20 個	
<b>1/2" 抗酸T形接頭</b>		
54626	2 個	
54646	20 個	

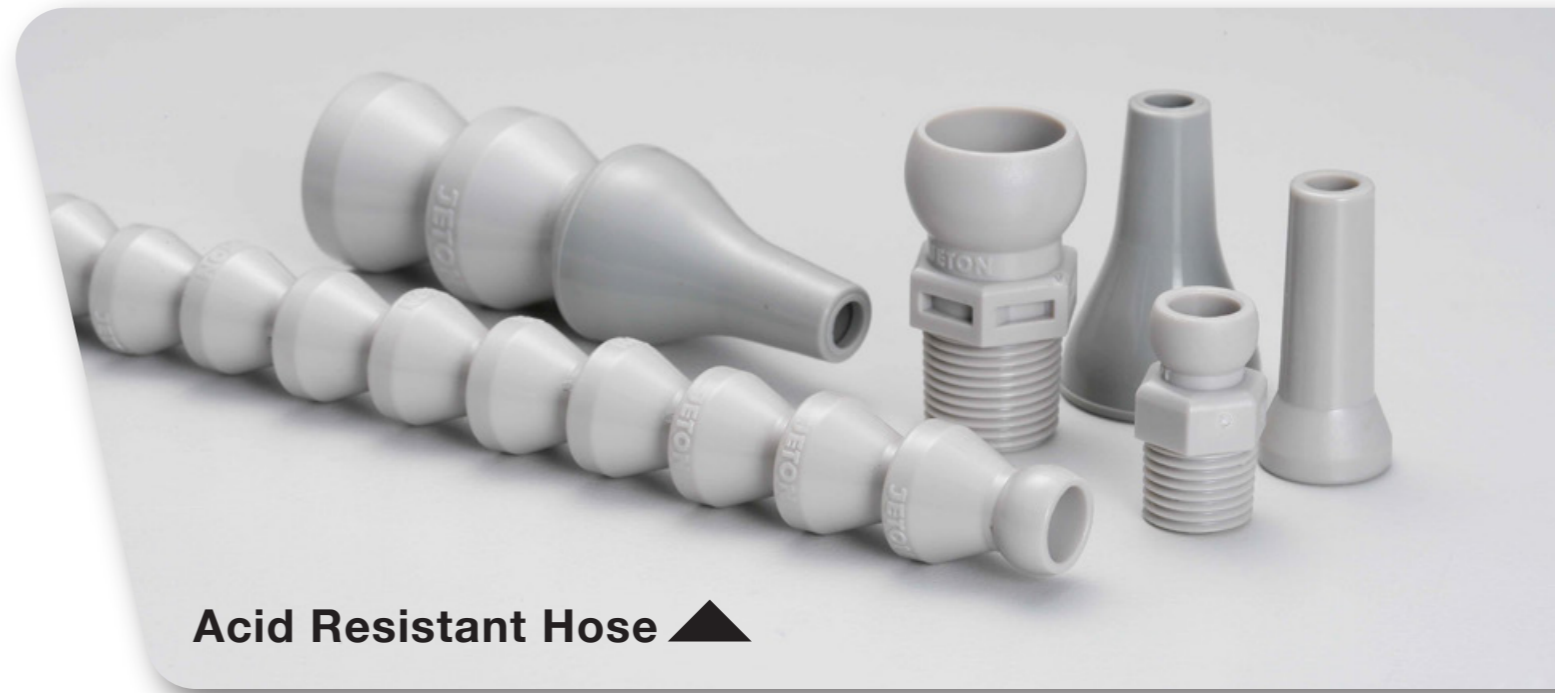

Acid Resistant Hose ▲

## 檔板組系列

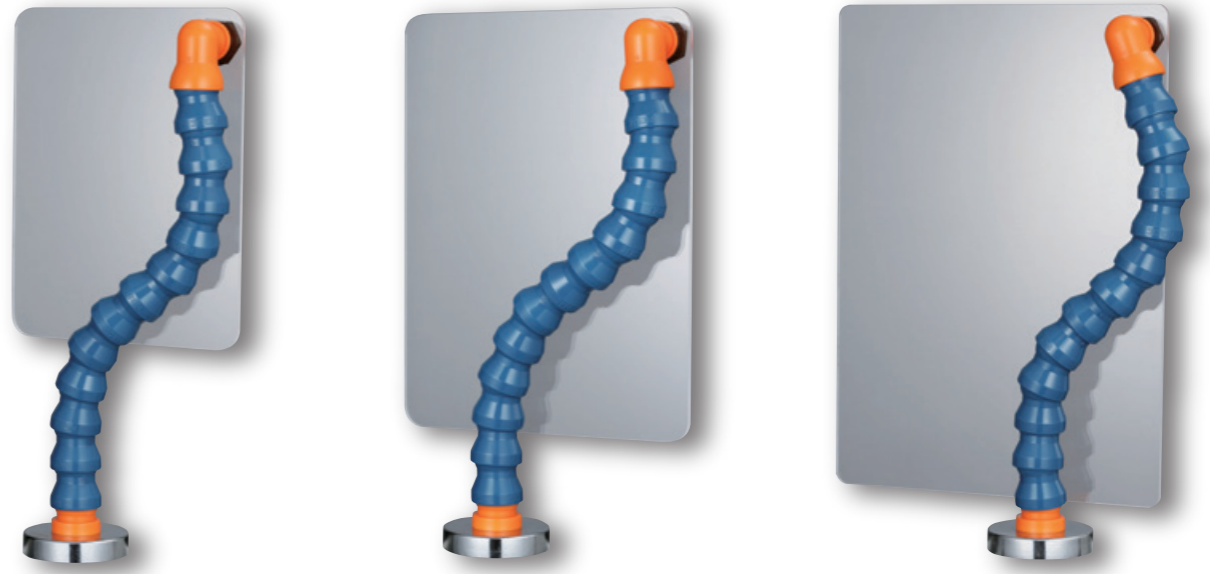

### 檔板組

#### 34101 (6" x 8")

磁座底部	1 組
3/4" 固定接頭	1 顆
12 顆 3/4" 曲管	1 條
3/4" L形公牙接頭	1 顆
螺帽	2 顆
壓克力板 (6" x 8")	1 片

#### 34102 (7-1/2" x 10")

磁座底部	1 組
3/4" 固定接頭	1 顆
12 顆 3/4" 曲管	1 條
3/4" L形公牙接頭	1 顆
螺帽	2 顆
壓克力板 (7-1/2" x 10")	1 片

#### 34103 (8-1/2" x 12")

磁座底部	1 組
3/4" 固定接頭	1 顆
12 顆 3/4" 曲管	1 條
3/4" L形公牙接頭	1 顆
螺帽	2 顆
壓克力板 (8-1/2" x 12")	1 片



## 磁性座系列



### 87011 磁座組

磁力 On-Off

- 磁座底部 (W5 X L6.5 X H5cm) 1 組
- 20 顆 1/4" 曲管 3 條
- 1" 扇形噴嘴 3 顆
- 1/4" PT 接頭 3 顆
- 1/4" 銅質開關 3 顆
- 5/16" 插管接頭 1 顆



### 87002 磁座組

磁力 On-Off

- 磁座底部 (W5 X L6.5 X H5cm) 1 組
- 20 顆 1/4" 曲管 2 條
- 1" 扇形噴嘴 2 顆
- 1/4" PT 接頭 2 顆
- 1/4" 銅質開關 2 顆
- 5/16" 插管接頭 1 顆

### 88003 磁座組

- 磁座底部 1 組
- 10 顆 1/4" 曲管 1 條
- 1" 扇形噴嘴 1 顆
- 1/4" PT 公牙接頭 1 顆
- 5/16" 插管接頭 1 顆



### 88005 磁座組

- 磁座底部 1 組
- 10 顆 1/4" 曲管 1 條
- 1" 扇形噴嘴 1 顆
- 1/4" PT 公牙凡而 1 顆
- 5/16" 插管接頭 1 顆



### 88103 磁座組

- 磁座底部 1 組
- 20 顆 1/4" 曲管 1 條
- 1" 扇形噴嘴 1 顆
- 1/4" PT 公牙接頭 1 顆
- 5/16" 插管接頭 1 顆



### 88105 磁座組

- 磁座底部 1 組
- 20 顆 1/4" 曲管 1 條
- 1" 扇形噴嘴 1 顆
- 1/4" PT 公牙凡而 1 顆
- 5/16" 插管接頭 1 顆

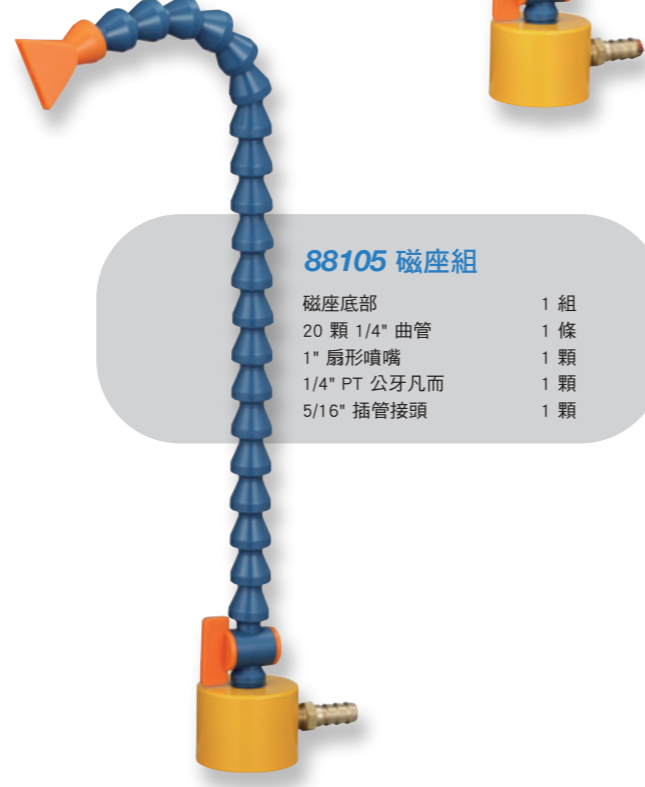

## 1/4" 系列規格圖

 14.5 20 Ø15.9 Ø12.5 Min-Dia 69mm 最大彎曲角度: 24°	 15.9 30.3 Ø1.5 Ø3.9	 35.4 27.5 31.1	 29.8 19 21.8 Ø2.3	 33.8 32.1
<b>82021+82021</b>	<b>82022</b>	<b>82722</b>	<b>82226</b>	<b>62426</b>
 26.3 10 1/8" PT牙	 21.2 7/16"-20 UNF牙	 15.9 30.1 Ø3.1 Ø7.55	 27.5 31.1 13 40.1	 33.8 28.1 24.48 11.9 28.42 17.4 Ø5.1 Ø1.8
<b>82025</b>	<b>82014</b>	<b>82023</b>	<b>82723</b>	<b>62423</b>
 26.4 13 1/4" PT牙	 27 Ø12.53 26.7	 15.88 35 Ø6.3 Ø9.93	 27.5 31.1 16 44.8	 14.85 22.3 5/8"-18 UNF牙
<b>82026</b>	<b>82028</b>	<b>82024</b>	<b>82724</b>	<b>52416</b>
 29.8 13 1/4" PT牙	 19	 24.8 19.8 Ø1.8 Ø4.1	 25.4 19.8 Ø3 Ø5.6	 45.8 39.78 46.8 Ø1.16
<b>82029</b>	<b>82011</b>	<b>82223</b>	<b>82224</b>	<b>82228</b>
 20.8 16.1 1/8" NPT牙	 25.8 23.1	 41.6 16.6 25.1 Ø21.2	 26.6 20 Ø6.1 Ø9	 45.8 41 46.9 Ø1.5*16
<b>82012</b>	<b>62420</b>	<b>82725</b>	<b>82225</b>	<b>82229</b>
 24.9 16.7 1/4" PT牙	 1.7 29.5 25 28.6	 1.3 30 10 15.9 7	 9 9 20.8 89.35 184 9A.65 28°	 45.1 65.2 70 Ø1.8*20
<b>82052</b>	<b>82027</b>	<b>82017</b>	<b>82220</b>	<b>82227</b>
 30.9 28 Ø15.7	 27.9 11 Ø15.7	 27.9 11 15.7 11 1.5	 27.8 11.11 Ø11.7	 27.8 11.16 Ø11.5
<b>82053</b>	<b>82054</b>	<b>82055</b>	<b>82056</b>	<b>82057</b>

**3/8" 系列規格圖**

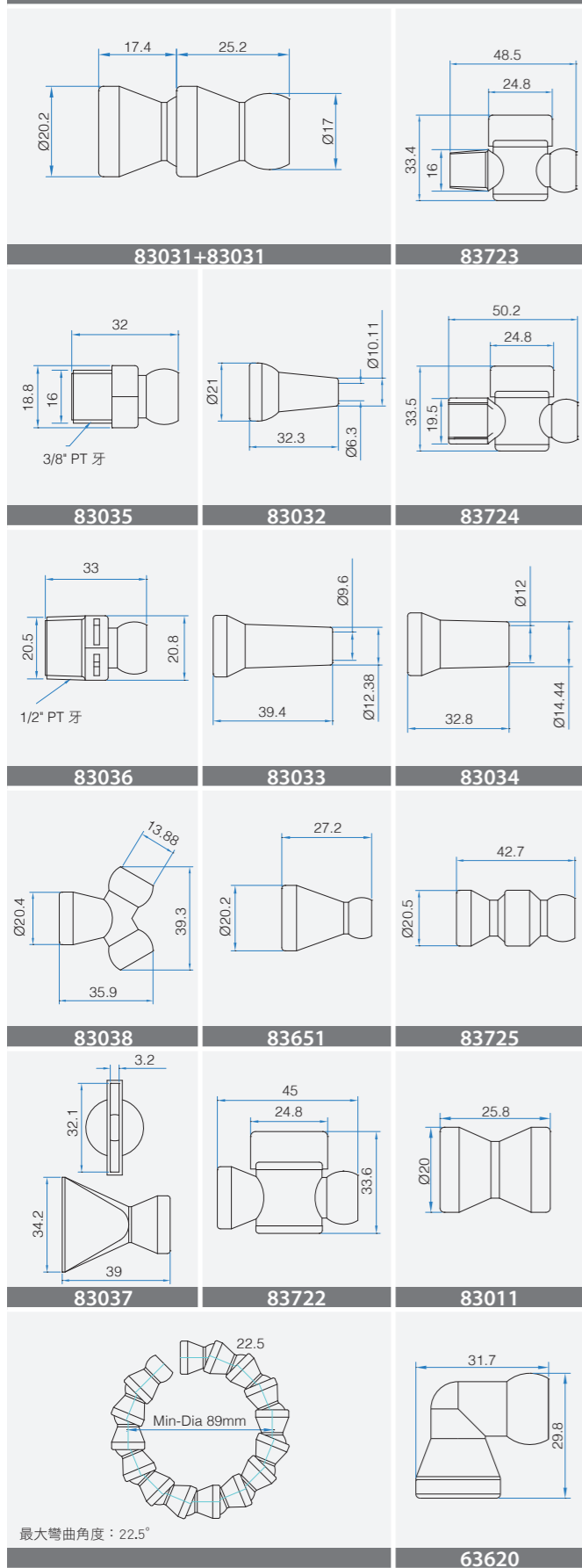

**1/2" 系列規格圖**

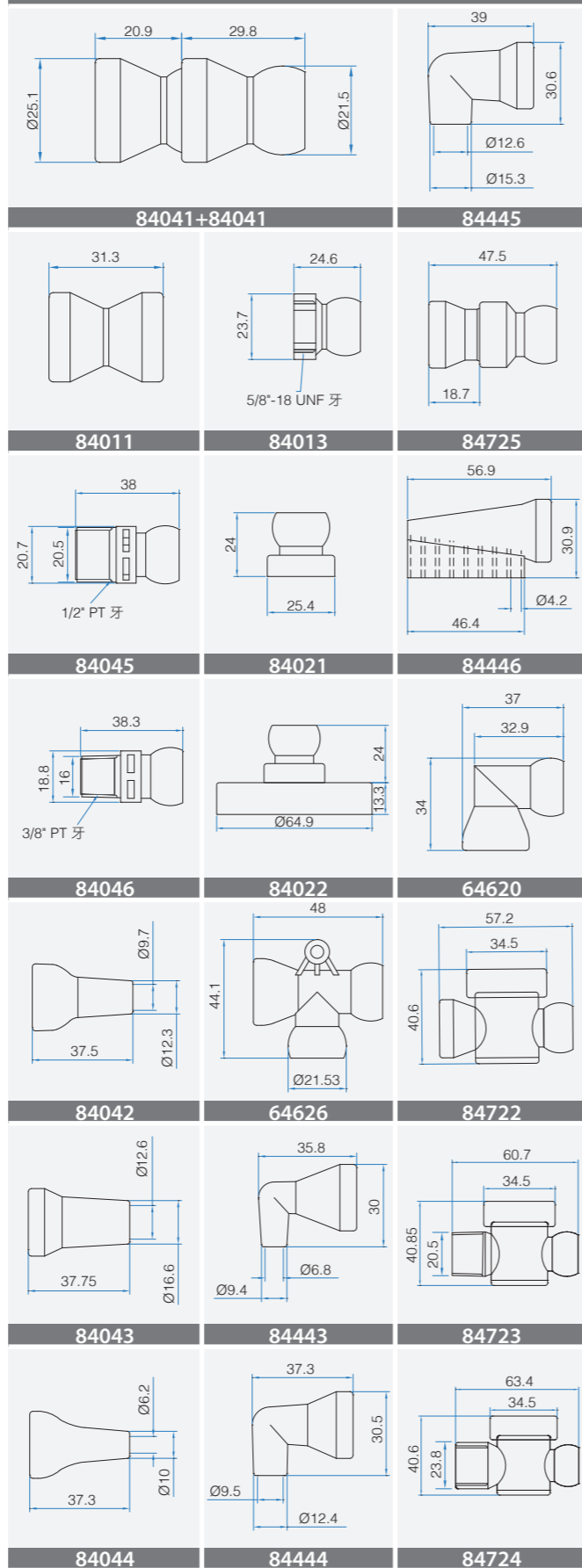

**1/2" 系列規格圖**

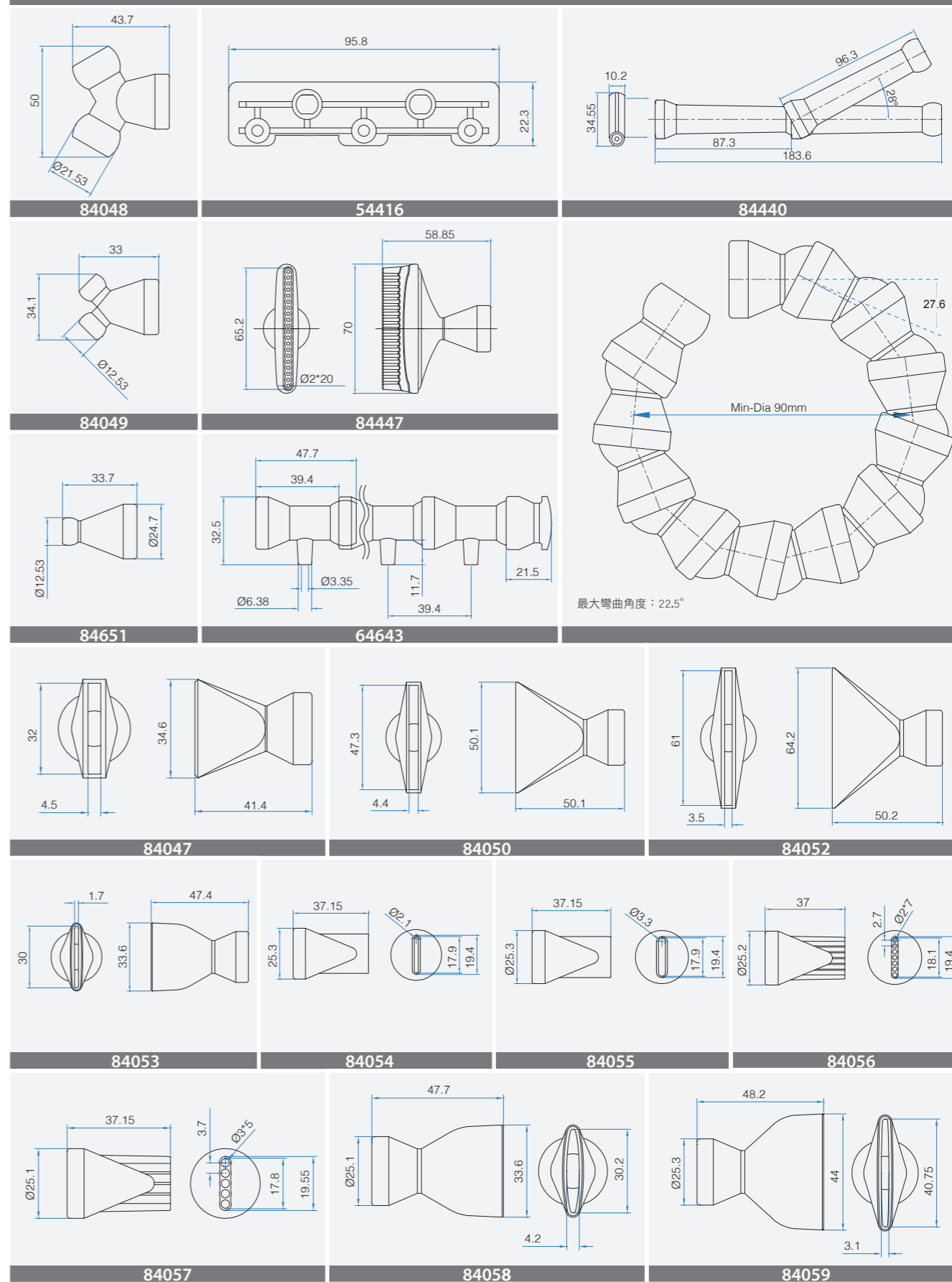



3/4" 系列規格圖

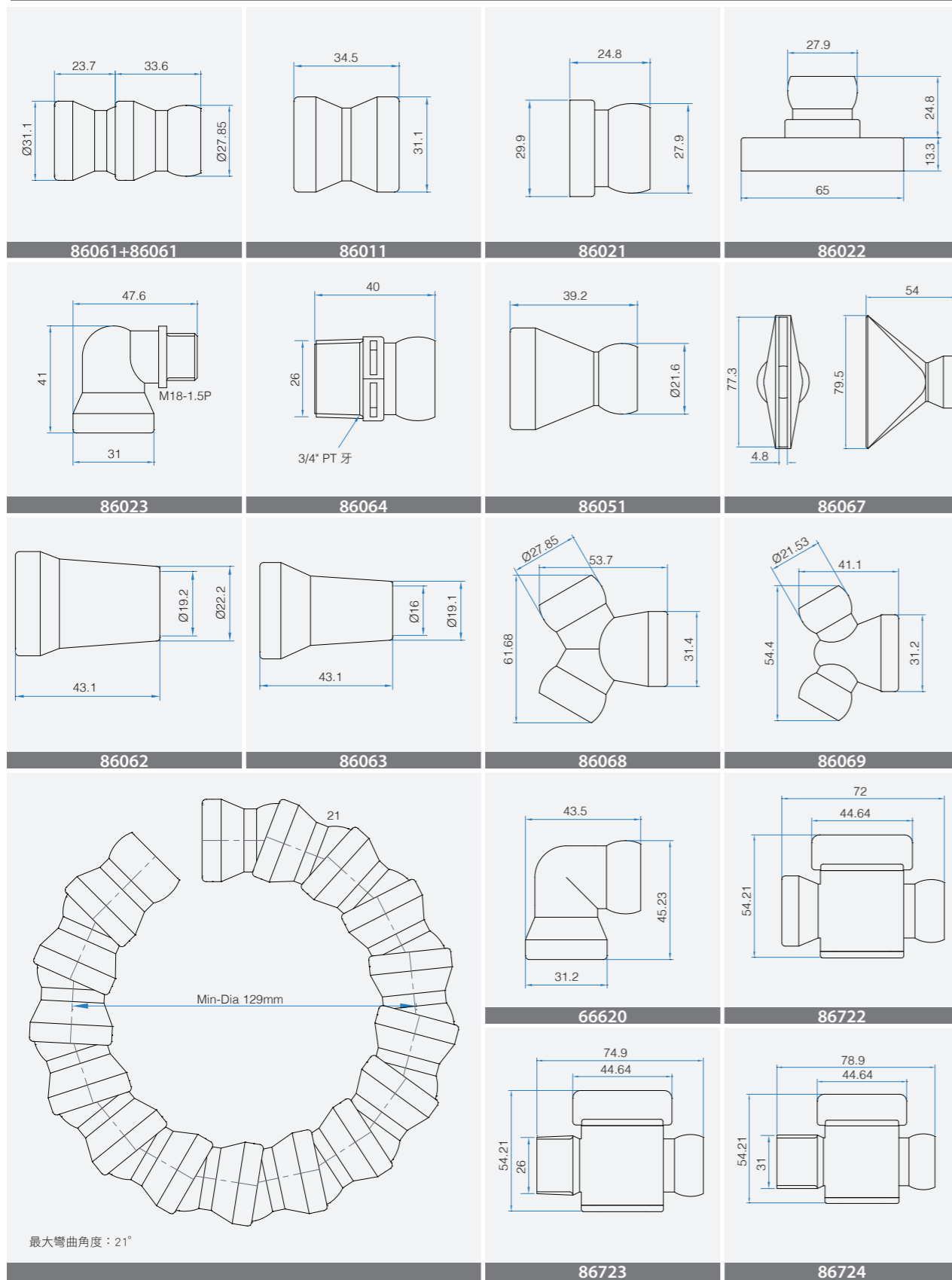

2 1/2" 系列規格圖

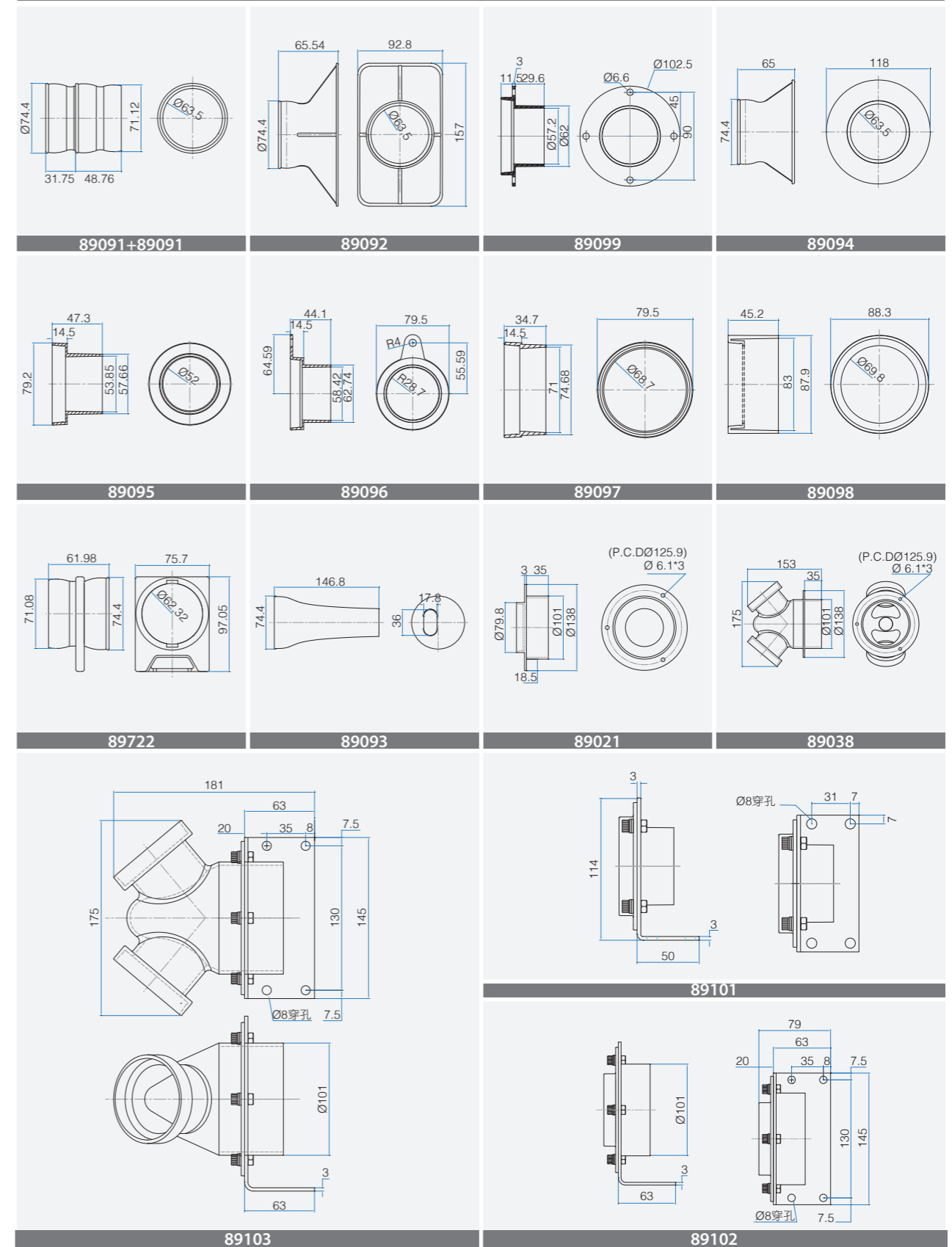



# JETON

## 高壓萬向噴嘴

### 高壓萬向噴嘴

High Pressure Adjustable Nozzle

高壓萬向噴嘴能提高工作效率，產品精度，保護切削刀具壽命，縮短工時，降低成本。是提升競爭力的利器。

- ▶ 特殊的機構設計，噴嘴傾斜34°後可做360°迴轉的角度調整，調整噴射範圍廣。
- ▶ 選用高等材質，配合精確組裝，使高壓萬向噴嘴發揮最大的功能。
- ▶ 耐壓30kgf/cm<sup>2</sup>，超高壓系列可耐壓100kgf/cm<sup>2</sup>。
- ▶ 角度調整範圍廣大，且容易調整。
- ▶ 定位穩定、精確，不會反彈。
- ▶ 適用各種機械的冷卻噴水、吹氣。

#### 壓力單位換算表：

Kgf/cm <sup>2</sup>	Bar	KPa	PSI	Torr mmHg	atm
1	= 0.981	98.1	14.2	735.56	0.968
30	= 29.43	2943	426	22066.8	29.04
100	= 98.1	9810	1420	73556	96.8



#### 斜噴式高壓萬向噴嘴

噴射方向與固定方向成一夾角，適用於偏向噴射冷卻，如CNC車床的刀塔。



#### 直噴式高壓萬向噴嘴

噴射方向與固定方向成一直線，適用於中心加工機、研磨機及各種加工母機。



#### 鑲入式高壓萬向噴嘴

噴射方向與固定方向成一直線，固定方式為緊密配合鑲入，適用於各種工作母機。



#### 鑲入式斜噴高壓萬向噴嘴

噴射方向與固定方向成一夾角，固定方式為緊密配合鑲入，適用於各種工作母機。



#### 360度斜噴式高壓萬向噴嘴

噴射方向與固定方向成一夾角，適用於偏向噴射冷卻，如CNC車床的刀塔。



#### 超高壓萬向噴嘴

可承受 100 公斤的水壓，噴射位置穩固，不會因為水壓過大而改變噴射位置。



## 斜噴式高壓萬向噴嘴

Inclined-Injection High Pressure Adjustable Nozzle

專利認證

噴射方向與固定方向成一夾角，非常適合調整側邊方向噴射，尤其是 CNC 車床刀塔的噴水冷卻。

- 容易調整角度。
- 定位精確穩固，不會反彈。
- 加工後工件清潔。
- 集中「水」力，準確噴射切削刀具，確保加工過程中，刀具的充份冷卻，延長刀具使用壽命。
- 強力的噴射冷卻，使得車屑帶不會纏繞在車刀，加工工作精確，表面光滑。
- 適用各種機械的噴水冷卻，噴氣。



型號	規格	主要尺寸								單位(mm)
		D	螺紋(S)	L	L1	L2	D1	B1	六角面(B)	
JTAP-1/8-10-4	1/8"PT-Φ4*10L	4	PT 1/8"	10	10	17.5	6	6	17	
JTAP-1/8-10-2	1/8"PT-Φ2*10L	2	PT 1/8"	10	10	17.5	6	6	17	
JTAP-1/8-10-1	1/8"PT-Φ1*10L	1	PT 1/8"	10	10	17.5	6	6	17	
JTAP-1/8-30-4	1/8"PT-Φ4*30L	4	PT 1/8"	30	10	17.5	6	6	17	
JTAP-1/8-30-2	1/8"PT-Φ2*30L	2	PT 1/8"	30	10	17.5	6	6	17	
JTAP-1/8-30-1	1/8"PT-Φ1*30L	1	PT 1/8"	30	10	17.5	6	6	17	
JTAP-1/8-50-4	1/8"PT-Φ4*50L	4	PT 1/8"	50	10	17.5	6	6	17	
JTAP-1/8-50-2	1/8"PT-Φ2*50L	2	PT 1/8"	50	10	17.5	6	6	17	
JTAP-1/8-50-1	1/8"PT-Φ1*50L	1	PT 1/8"	50	10	17.5	6	6	17	

## 規格表

For Inclined-injection High Pressure Adjustable Nozzle

- 可耐壓30kgf/cm<sup>2</sup>

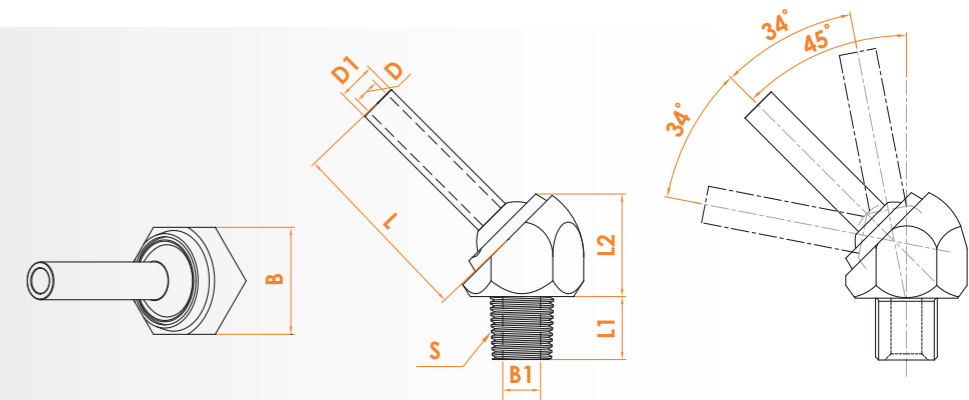

型號	規格	主要尺寸								單位(mm)
		D	螺紋(S)	L	L1	L2	D1	B1	六角面(B)	
JTAP-1/4-10-4	1/4"PT-Φ4*10L	4	PT 1/4"	10	10	17.5	6	6	17	
JTAP-1/4-10-2	1/4"PT-Φ2*10L	2	PT 1/4"	10	10	17.5	6	6	17	
JTAP-1/4-10-1	1/4"PT-Φ1*10L	1	PT 1/4"	10	10	17.5	6	6	17	
JTAP-1/4-30-4	1/4"PT-Φ4*30L	4	PT 1/4"	30	10	17.5	6	6	17	
JTAP-1/4-30-2	1/4"PT-Φ2*30L	2	PT 1/4"	30	10	17.5	6	6	17	
JTAP-1/4-30-1	1/4"PT-Φ1*30L	1	PT 1/4"	30	10	17.5	6	6	17	
JTAP-1/4-50-4	1/4"PT-Φ4*50L	4	PT 1/4"	50	10	17.5	6	6	17	
JTAP-1/4-50-2	1/4"PT-Φ2*50L	2	PT 1/4"	50	10	17.5	6	6	17	
JTAP-1/4-50-1	1/4"PT-Φ1*50L	1	PT 1/4"	50	10	17.5	6	6	17	
JTAP-3/8-20-6	3/8"PT-Φ6*20L	6	PT 3/8"	20	13	27.2	8	10	24	
JTAP-3/8-40-6	3/8"PT-Φ6*40L	6	PT 3/8"	40	13	27.2	8	10	24	
JTAP-3/8-60-6	3/8"PT-Φ6*60L	6	PT 3/8"	60	13	27.2	8	10	24	
JTAP-1/2-30-8	1/2"PT-Φ8*30L	8	PT 1/2"	30	18	35.3	10	12	32	
JTAP-1/2-50-8	1/2"PT-Φ8*50L	8	PT 1/2"	50	18	35.3	10	12	32	
JTAP-1/2-70-8	1/2"PT-Φ8*70L	8	PT 1/2"	70	18	35.3	10	12	32	

  

型號	規格	主要尺寸								單位(mm)
		D	螺紋(S)	L	L1	L2	D1	B1	六角面(B)	
JTAN-1/8-10-4	1/8"NPT-Φ4*10L	4	NPT 1/8"	10	10	17.5	6	6	17	
JTAN-1/8-10-2	1/8"NPT-Φ2*10L	2	NPT 1/8"	10	10	17.5	6	6	17	
JTAN-1/8-10-1	1/8"NPT-Φ1*10L	1	NPT 1/8"	10	10	17.5	6	6	17	
JTAN-1/8-30-4	1/8"NPT-Φ4*30L	4	NPT 1/8"	30	10	17.5	6	6	17	
JTAN-1/8-30-2	1/8"NPT-Φ2*30L	2	NPT 1/8"	30	10	17.5	6	6	17	
JTAN-1/8-30-1	1/8"NPT-Φ1*30L	1	NPT 1/8"	30	10	17.5	6	6	17	
JTAN-1/8-50-4	1/8"NPT-Φ4*50L	4	NPT 1/8"	50	10	17.5	6	6	17	
JTAN-1/8-50-2	1/8"NPT-Φ2*50L	2	NPT 1/8"	50	10	17.5	6	6	17	
JTAN-1/8-50-1	1/8"NPT-Φ1*50L	1	NPT 1/8"	50	10	17.5	6	6	17	
JTAN-1/4-10-4	1/4"NPT-Φ4*10L	4	NPT 1/4"	10	10	17.5	6	6	17	
JTAN-1/4-10-2	1/4"NPT-Φ2*10L	2	NPT 1/4"	10	10	17.5	6	6	17	
JTAN-1/4-10-1	1/4"NPT-Φ1*10L	1	NPT 1/4"	10	10	17.5	6	6	17	
JTAN-1/4-30-4	1/4"NPT-Φ4*30L	4	NPT 1/4"	30	10	17.5	6	6	17	
JTAN-1/4-30-2	1/4"NPT-Φ2*30L	2	NPT 1/4"	30	10	17.5	6	6	17	
JTAN-1/4-30-1	1/4"NPT-Φ1*30L	1	NPT 1/4"	30	10	17.5	6	6	17	
JTAN-1/4-50-4	1/4"NPT-Φ4*50L	4	NPT 1/4"	50	10	17.5	6	6	17	
JTAN-1/4-50-2	1/4"NPT-Φ2*50L	2	NPT 1/4"	50	10	17.5	6	6	17	
JTAN-1/4-50-1	1/4"NPT-Φ1*50L	1	NPT 1/4"	50	10	17.5	6	6	17	
JTAN-3/8-20-6	3/8"NPT-Φ6*20L	6	NPT 3/8"	20	13	27.2	8	10	24	
JTAN-3/8-40-6	3/8"NPT-Φ6*40L	6	NPT 3/8"	40	13	27.2	8	10	24	
JTAN-3/8-60-6	3/8"NPT-Φ6*60L	6	NPT 3/8"	60	13	27.2	8	10	24	
JTAN-1/2-30-8	1/2"NPT-Φ8*30L	8	NPT 1/2"	30	18	35.3	10	12	32	
JTAN-1/2-50-8	1/2"NPT-Φ8*50L	8	NPT 1/2"	50	18	35.3	10	12	32	
JTAN-1/2-70-8	1/2"NPT-Φ8*70L	8	NPT 1/2"	70	18	35.3	10	12	32	

# 規格表

For Inclined-Injection  
High Pressure Adjustable Nozzle

● 可耐壓30kgf/cm<sup>2</sup>

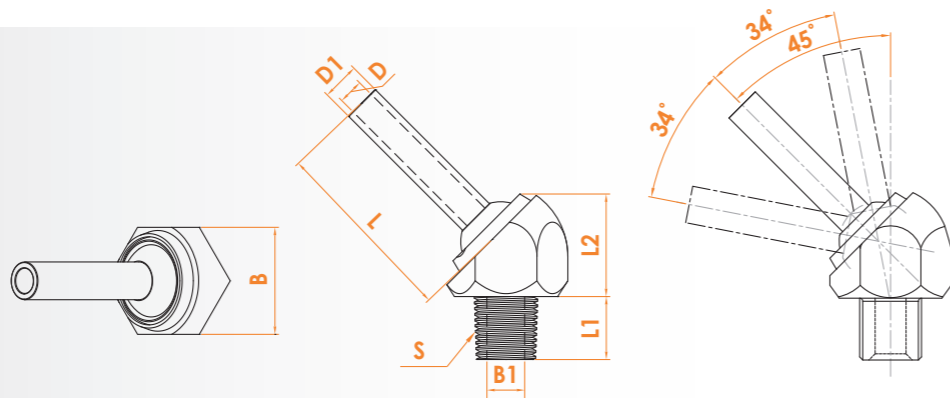

型號	規格	主要尺寸							單位(mm)	
		D	螺紋(S)	L	L1	L2	D1	B1	六角面(B)	
JTAM-10-10-4	M10*1.25P-Φ4*10L	4	M10*1.25P	10	10	17.5	6	6	17	
JTAM-10-10-2	M10*1.25P-Φ2*10L	2	M10*1.25P	10	10	17.5	6	6	17	
JTAM-10-10-1	M10*1.25P-Φ1*10L	1	M10*1.25P	10	10	17.5	6	6	17	
JTAM-10-30-4	M10*1.25P-Φ4*30L	4	M10*1.25P	30	10	17.5	6	6	17	
JTAM-10-30-2	M10*1.25P-Φ2*30L	2	M10*1.25P	30	10	17.5	6	6	17	
JTAM-10-30-1	M10*1.25P-Φ1*30L	1	M10*1.25P	30	10	17.5	6	6	17	
JTAM-10-50-4	M10*1.25P-Φ4*50L	4	M10*1.25P	50	10	17.5	6	6	17	
JTAM-10-50-2	M10*1.25P-Φ2*50L	2	M10*1.25P	50	10	17.5	6	6	17	
JTAM-10-50-1	M10*1.25P-Φ1*50L	1	M10*1.25P	50	10	17.5	6	6	17	

型號	規格	主要尺寸							單位(mm)	
		D	螺紋(S)	L	L1	L2	D1	B1	六角面(B)	
JTAP2-1/8-10-3	1/8"PT-Φ3*10L	3	PT 1/8"	10	10	14.8	5	5	14	
JTAP2-1/8-20-3	1/8"PT-Φ3*20L	3	PT 1/8"	20	10	14.8	5	5	14	
JTAP2-3/8-10-4	3/8"PT-Φ4*10L	4	PT 3/8"	10	10	17.5	6	6	17	
JTAP2-3/8-10-2	3/8"PT-Φ2*10L	2	PT 3/8"	10	10	17.5	6	6	17	
JTAP2-3/8-10-1	3/8"PT-Φ1*10L	1	PT 3/8"	10	10	17.5	6	6	17	
JTAP2-3/8-30-4	3/8"PT-Φ4*30L	4	PT 3/8"	30	10	17.5	6	6	17	
JTAP2-3/8-30-2	3/8"PT-Φ2*30L	2	PT 3/8"	30	10	17.5	6	6	17	
JTAP2-3/8-30-1	3/8"PT-Φ1*30L	1	PT 3/8"	30	10	17.5	6	6	17	
JTAP2-3/8-50-4	3/8"PT-Φ4*50L	4	PT 3/8"	50	10	17.5	6	6	17	
JTAP2-3/8-50-2	3/8"PT-Φ2*50L	2	PT 3/8"	50	10	17.5	6	6	17	
JTAP2-3/8-50-1	3/8"PT-Φ1*50L	1	PT 3/8"	50	10	17.5	6	6	17	

型號	規格	主要尺寸							單位(mm)	
		D	螺紋(S)	L	L1	L2	D1	B1	六角面(B)	
JTAN2-1/8-10-3	1/8"NPT-Φ3*10L	3	NPT 1/8"	10	10	14.8	5	5	14	
JTAN2-1/8-20-3	1/8"NPT-Φ3*20L	3	NPT 1/8"	20	10	14.8	5	5	14	
JTAN2-3/8-10-4	3/8"NPT-Φ4*10L	4	NPT 3/8"	10	10	17.5	6	6	17	
JTAN2-3/8-10-2	3/8"NPT-Φ2*10L	2	NPT 3/8"	10	10	17.5	6	6	17	
JTAN2-3/8-10-1	3/8"NPT-Φ1*10L	1	NPT 3/8"	10	10	17.5	6	6	17	
JTAN2-3/8-30-4	3/8"NPT-Φ4*30L	4	NPT 3/8"	30	10	17.5	6	6	17	
JTAN2-3/8-30-2	3/8"NPT-Φ2*30L	2	NPT 3/8"	30	10	17.5	6	6	17	
JTAN2-3/8-30-1	3/8"NPT-Φ1*30L	1	NPT 3/8"	30	10	17.5	6	6	17	
JTAN2-3/8-50-4	3/8"NPT-Φ4*50L	4	NPT 3/8"	50	10	17.5	6	6	17	
JTAN2-3/8-50-2	3/8"NPT-Φ2*50L	2	NPT 3/8"	50	10	17.5	6	6	17	
JTAN2-3/8-50-1	3/8"NPT-Φ1*50L	1	NPT 3/8"	50	10	17.5	6	6	17	

型號	規格	主要尺寸							單位(mm)	
		D	螺紋(S)	L	L1	L2	D1	B1	六角面(B)	
JTAM2-8-10-3	M8*1.25P-Ø3*10L	3	M8*1.25P	10	10	14.8	5	4.5	14	
JTAM2-8-20-3	M8*1.25P-Ø3*20L	3	M8*1.25P	20	10	14.8	5	4.5	14	
JTAM2-6-10-3	M6*1.0P-Ø3*10L	3	M6*1.0P	10	10	14.8	8	4.5	14	
JTAM2-6-20-3	M6*1.0P-Ø3*20L	3	M6*1.0P	20	10	14.8	8	4.5	14	



## 直噴式高壓萬向噴嘴

Direct-Injection High Pressure Adjustable Nozzle

噴射方向與固定方向成一直線，固定方式以螺旋固定之，廣泛適用各種機械的噴水冷卻，噴氣等。

- 調整角度容易。
- 定位精確穩固，不會反彈。
- 集中「水」力，準確噴射銑刀或鑽頭，確保加工過程中銑刀或鑽頭的充份冷卻，延長其使用壽命。
- 適用各種機械的噴水冷卻，噴氣。



# 規格表

For Direct-Injection  
High Pressure Adjustable Nozzle

● 可耐壓30kgf/cm<sup>2</sup>

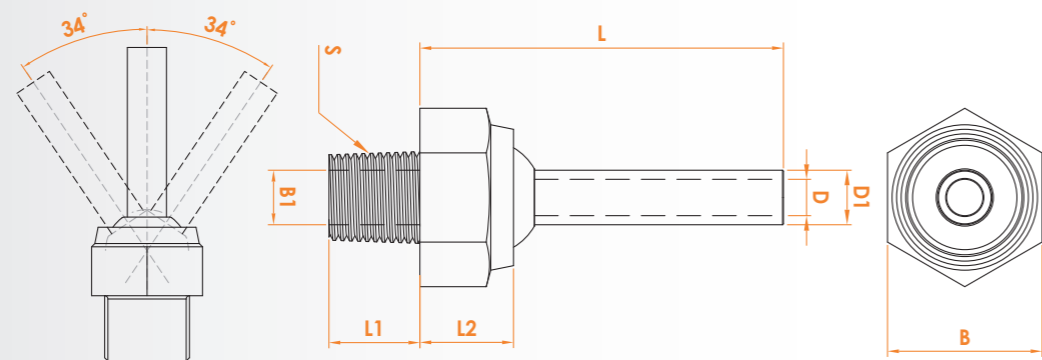

型號	規格	主要尺寸								單位(mm)
		D	螺紋(S)	L	L1	L2	D1	B1	六角面(B)	
JTSP-1/8-20-4	1/8"PT-Φ4*20L	4	PT 1/8"	20	10	10.5	6	6	17	
JTSP-1/8-20-2	1/8"PT-Φ2*20L	2	PT 1/8"	20	10	10.5	6	6	17	
JTSP-1/8-20-1	1/8"PT-Φ1*20L	1	PT 1/8"	20	10	10.5	6	6	17	
JTSP-1/8-40-4	1/8"PT-Φ4*40L	4	PT 1/8"	40	10	10.5	6	6	17	
JTSP-1/8-40-2	1/8"PT-Φ2*40L	2	PT 1/8"	40	10	10.5	6	6	17	
JTSP-1/8-40-1	1/8"PT-Φ1*40L	1	PT 1/8"	40	10	10.5	6	6	17	
JTSP-1/8-60-4	1/8"PT-Φ4*60L	4	PT 1/8"	60	10	10.5	6	6	17	
JTSP-1/8-60-2	1/8"PT-Φ2*60L	2	PT 1/8"	60	10	10.5	6	6	17	
JTSP-1/8-60-1	1/8"PT-Φ1*60L	1	PT 1/8"	60	10	10.5	6	6	17	
JTSP-1/4-20-4	1/4"PT-Φ4*20L	4	PT 1/4"	20	10	10.5	6	6	17	
JTSP-1/4-20-2	1/4"PT-Φ2*20L	2	PT 1/4"	20	10	10.5	6	6	17	
JTSP-1/4-20-1	1/4"PT-Φ1*20L	1	PT 1/4"	20	10	10.5	6	6	17	
JTSP-1/4-40-4	1/4"PT-Φ4*40L	4	PT 1/4"	40	10	10.5	6	6	17	
JTSP-1/4-40-2	1/4"PT-Φ2*40L	2	PT 1/4"	40	10	10.5	6	6	17	
JTSP-1/4-40-1	1/4"PT-Φ1*40L	1	PT 1/4"	40	10	10.5	6	6	17	
JTSP-1/4-60-4	1/4"PT-Φ4*60L	4	PT 1/4"	60	10	10.5	6	6	17	
JTSP-1/4-60-2	1/4"PT-Φ2*60L	2	PT 1/4"	60	10	10.5	6	6	17	
JTSP-1/4-60-1	1/4"PT-Φ1*60L	1	PT 1/4"	60	10	10.5	6	6	17	
JTSP-3/8-30-6	3/8"PT-Φ6*30L	6	PT 3/8"	30	13	15	8	10	24	
JTSP-3/8-50-6	3/8"PT-Φ6*50L	6	PT 3/8"	50	13	15	8	10	24	
JTSP-3/8-70-6	3/8"PT-Φ6*70L	6	PT 3/8"	70	13	15	8	10	24	
JTSP-1/2-40-8	1/2"PT-Φ8*40L	8	PT 1/2"	40	18	21	10	12	32	
JTSP-1/2-60-8	1/2"PT-Φ8*60L	8	PT 1/2"	60	18	21	10	12	32	
JTSP-1/2-80-8	1/2"PT-Φ8*80L	8	PT 1/2"	80	18	21	10	12	32	

型號	規格	主要尺寸								單位(mm)
		D	螺紋(S)	L	L1	L2	D1	B1	六角面(B)	
JTSN-1/4-20-4	1/4"NPT-Φ4*20L	4	NPT 1/4"	20	10	10.5	6	6	17	
JTSN-1/4-20-2	1/4"NPT-Φ2*20L	2	NPT 1/4"	20	10	10.5	6	6	17	
JTSN-1/4-20-1	1/4"NPT-Φ1*20L	1	NPT 1/4"	20	10	10.5	6	6	17	
JTSN-1/4-40-4	1/4"NPT-Φ4*40L	4	NPT 1/4"	40	10	10.5	6	6	17	
JTSN-1/4-40-2	1/4"NPT-Φ2*40L	2	NPT 1/4"	40	10	10.5	6	6	17	
JTSN-1/4-40-1	1/4"NPT-Φ1*40L	1	NPT 1/4"	40	10	10.5	6	6	17	
JTSN-1/4-60-4	1/4"NPT-Φ4*60L	4	NPT 1/4"	60	10	10.5	6	6	17	
JTSN-1/4-60-2	1/4"NPT-Φ2*60L	2	NPT 1/4"	60	10	10.5	6	6	17	
JTSN-1/4-60-1	1/4"NPT-Φ1*60L	1	NPT 1/4"	60	10	10.5	6	6	17	
JTSN-3/8-30-6	3/8"NPT-Φ6*30L	6	NPT 3/8"	30	13	15	8	10	24	
JTSN-3/8-50-6	3/8"NPT-Φ6*50L	6	NPT 3/8"	50	13	15	8	10	24	
JTSN-3/8-70-6	3/8"NPT-Φ6*70L	6	NPT 3/8"	70	13	15	8	10	24	
JTSN-1/2-40-8	1/2"NPT-Φ8*40L	8	NPT 1/2"	40	18	21	10	12	32	
JTSN-1/2-60-8	1/2"NPT-Φ8*60L	8	NPT 1/2"	60	18	21	10	12	32	
JTSN-1/2-80-8	1/2"NPT-Φ8*80L	8	NPT 1/2"	80	18	21	10	12	32	

型號	規格	主要尺寸								單位(mm)
		D	螺紋(S)	L	L1	L2	D1	B1	六角面(B)	
JTSM-10-15-4	M10*1.25P*Φ4*15L	4	M10*1.25P	15	10	10.5	6	6	17	
JTSM-10-15-2	M10*1.25P*Φ2*15L	2	M10*1.25P	15	10	10.5	6	6	17	
JTSM-10-15-1	M10*1.25P*Φ1*15L	1	M10*1.25P	15	10	10.5	6	6	17	
JTSM-10-20-4	M10*1.25P*Φ4*20L	4	M10*1.25P	20	10	10.5	6	6	17	
JTSM-10-20-2	M10*1.25P*Φ2*20L	2	M10*1.25P	20	10	10.5	6	6	17	
JTSM-10-20-1	M10*1.25P*Φ1*20L	1	M10*1.25P	20	10	10.5	6	6	17	
JTSM-10-40-4	M10*1.25P*Φ4*40L	4	M10*1.25P	40	10	10.5	6	6	17	
JTSM-10-40-2	M10*1.25P*Φ2*40L	2	M10*1.25P	40	10	10.5	6	6	17	
JTSM-10-40-1	M10*1.25P*Φ1*40L	1	M10*1.25P	40	10	10.5	6	6	17	
JTSM-10-60-4	M10*1.25P*Φ4*60L	4	M10*1.25P	60	10	10.5	6	6	17	
JTSM-10-60-2	M10*1.25P*Φ2*60L	2	M10*1.25P	60	10	10.5	6	6	17	
JTSM-10-60-1	M10*1.25P*Φ1*60L	1	M10*1.25P	60	10	10.5	6	6	17	
JTSM-20-30-6	M20*1.5P*Φ6*30L	6	M20*1.5P	30	13	15	8	10	24	
JTSM-20-50-6	M20*1.5P*Φ6*50L	6	M20*1.5P	50	13	15	8	10	24	
JTSM-20-70-6	M20*1.5P*Φ6*70L	6	M20*1.5P	70	13	15	8	10	24	
JTSM-24-40-8	M24*2.0P*Φ8*40L	8	M24*2.0P	40	18	21	10	12	32	
JTSM-24-60-8	M24*2.0P*Φ8*60L	8	M24*2.0P	60	18	21	10	12	32	
JTSM-24-80-8	M24*2.0P*Φ8*80L	8	M24*2.0P	80	18	21	10	12	32	



## 360度斜噴式高壓萬向噴嘴

360° Inclined-Injection High Pressure Adjustable Nozzle

專利認證

噴射方向與固定方向成一夾角，非常適合調整側邊方向噴射，尤其是CNC車床刀塔的噴水冷卻。

- 容易調整角度。
- 定位精確穩固，不會反彈。
- 加工後工件清潔。
- 集中「水」力，準確噴射切削刀具，確保加工過程中，刀具的充份冷卻，延長刀具使用壽命。
- 強力的噴射冷卻，使得車屑帶不會纏繞在車刀，加工工作精確，表面光滑。
- 適用各種機械的噴水冷卻，噴氣。
- 噴嘴固定後，可再360度旋轉調整噴射方向。

型號	規格	主要尺寸							單位(mm)	
		D	螺紋(S)	L	L1	L2	D1	B1	六角面(B)	
JTASP-1/8-10-4	1/8"PT-Φ4*10L	4	PT 1/8"	10	10	21.4	6	7	17	
JTASP-1/8-10-2	1/8"PT-Φ2*10L	2	PT 1/8"	10	10	21.4	6	7	17	
JTASP-1/8-10-1	1/8"PT-Φ1*10L	1	PT 1/8"	10	10	21.4	6	7	17	
JTASP-1/8-30-4	1/8"PT-Φ4*30L	4	PT 1/8"	30	10	21.4	6	7	17	
JTASP-1/8-30-2	1/8"PT-Φ2*30L	2	PT 1/8"	30	10	21.4	6	7	17	
JTASP-1/8-30-1	1/8"PT-Φ1*30L	1	PT 1/8"	30	10	21.4	6	7	17	
JTASP-1/8-50-4	1/8"PT-Φ4*50L	4	PT 1/8"	50	10	21.4	6	7	17	
JTASP-1/8-50-2	1/8"PT-Φ2*50L	2	PT 1/8"	50	10	21.4	6	7	17	
JTASP-1/8-50-1	1/8"PT-Φ1*50L	1	PT 1/8"	50	10	21.4	6	7	17	
JTASP-1/4-10-4	1/4"PT-Φ4*10L	4	PT 1/4"	10	10	21.4	6	7	17	
JTASP-1/4-10-2	1/4"PT-Φ2*10L	2	PT 1/4"	10	10	21.4	6	7	17	
JTASP-1/4-10-1	1/4"PT-Φ1*10L	1	PT 1/4"	10	10	21.4	6	7	17	
JTASP-1/4-30-4	1/4"PT-Φ4*30L	4	PT 1/4"	30	10	21.4	6	7	17	
JTASP-1/4-30-2	1/4"PT-Φ2*30L	2	PT 1/4"	30	10	21.4	6	7	17	
JTASP-1/4-30-1	1/4"PT-Φ1*30L	1	PT 1/4"	30	10	21.4	6	7	17	
JTASP-1/4-50-4	1/4"PT-Φ4*50L	4	PT 1/4"	50	10	21.4	6	7	17	
JTASP-1/4-50-2	1/4"PT-Φ2*50L	2	PT 1/4"	50	10	21.4	6	7	17	
JTASP-1/4-50-1	1/4"PT-Φ1*50L	1	PT 1/4"	50	10	21.4	6	7	17	

## 規格表

360° Inclined-Injection High Pressure Adjustable Nozzle

- 可耐壓30kgf/cm<sup>2</sup>

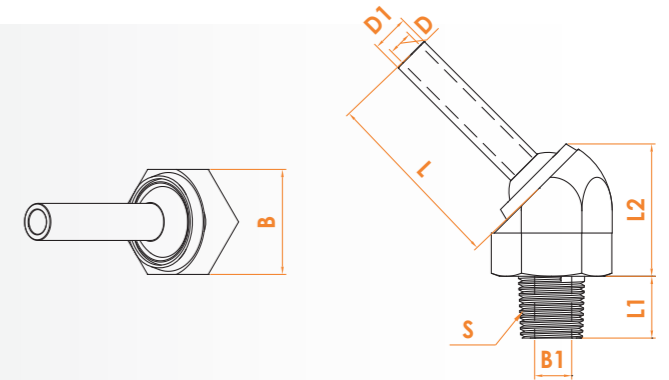

型號	規格	主要尺寸							單位(mm)	
		D	螺紋(S)	L	L1	L2	D1	B1	六角面(B)	
JTASP-3/8-10-4	3/8"PT-Φ4*10L	4	PT 3/8"	10	10	21.4	6	7	17	
JTASP-3/8-10-2	3/8"PT-Φ2*10L	2	PT 3/8"	10	10	21.4	6	7	17	
JTASP-3/8-10-1	3/8"PT-Φ1*10L	1	PT 3/8"	10	10	21.4	6	7	17	
JTASP-3/8-30-4	3/8"PT-Φ4*30L	4	PT 3/8"	30	10	21.4	6	7	17	
JTASP-3/8-30-2	3/8"PT-Φ2*30L	2	PT 3/8"	30	10	21.4	6	7	17	
JTASP-3/8-30-1	3/8"PT-Φ1*30L	1	PT 3/8"	30	10	21.4	6	7	17	
JTASP-3/8-50-4	3/8"PT-Φ4*50L	4	PT 3/8"	50	10	21.4	6	7	17	
JTASP-3/8-50-2	3/8"PT-Φ2*50L	2	PT 3/8"	50	10	21.4	6	7	17	
JTASP-3/8-50-1	3/8"PT-Φ1*50L	1	PT 3/8"	50	10	21.4	6	7	17	
JTASN-1/8-10-4	1/8"NPT-Φ4*10L	4	NPT 1/8"	10	10	21.4	6	7	17	
JTASN-1/8-10-2	1/8"NPT-Φ2*10L	2	NPT 1/8"	10	10	21.4	6	7	17	
JTASN-1/8-10-1	1/8"NPT-Φ1*10L	1	NPT 1/8"	10	10	21.4	6	7	17	
JTASN-1/8-30-4	1/8"NPT-Φ4*30L	4	NPT 1/8"	30	10	21.4	6	7	17	
JTASN-1/8-30-2	1/8"NPT-Φ2*30L	2	NPT 1/8"	30	10	21.4	6	7	17	
JTASN-1/8-30-1	1/8"NPT-Φ1*30L	1	NPT 1/8"	30	10	21.4	6	7	17	
JTASN-1/8-50-4	1/8"NPT-Φ4*50L	4	NPT 1/8"	50	10	21.4	6	7	17	
JTASN-1/8-50-2	1/8"NPT-Φ2*50L	2	NPT 1/8"	50	10	21.4	6	7	17	
JTASN-1/8-50-1	1/8"NPT-Φ1*50L	1	NPT 1/8"	50	10	21.4	6	7	17	
JTASN-1/4-10-4	1/4"NPT-Φ4*10L	4	NPT 1/4"	10	10	21.4	6	7	17	
JTASN-1/4-10-2	1/4"NPT-Φ2*10L	2	NPT 1/4"	10	10	21.4	6	7	17	
JTASN-1/4-10-1	1/4"NPT-Φ1*10L	1	NPT 1/4"	10	10	21.4	6	7	17	
JTASN-1/4-30-4	1/4"NPT-Φ4*30L	4	NPT 1/4"	30	10	21.4	6	7	17	
JTASN-1/4-30-2	1/4"NPT-Φ2*30L	2	NPT 1/4"	30	10	21.4	6	7	17	
JTASN-1/4-30-1	1/4"NPT-Φ1*30L	1	NPT 1/4"	30	10	21.4	6	7	17	
JTASN-1/4-50-4	1/4"NPT-Φ4*50L	4	NPT 1/4"	50	10	21.4	6	7	17	
JTASN-1/4-50-2	1/4"NPT-Φ2*50L	2	NPT 1/4"	50	10	21.4	6	7	17	
JTASN-1/4-50-1	1/4"NPT-Φ1*50L	1	NPT 1/4"	50	10	21.4	6	7	17	
JTASN-3/8-10-4	3/8"NPT-Φ4*10L	4	NPT 3/8"	10	10	21.4	6	7	17	
JTASN-3/8-10-2	3/8"NPT-Φ2*10L	2	NPT 3/8"	10	10	21.4	6	7	17	
JTASN-3/8-10-1	3/8"NPT-Φ1*10L	1	NPT 3/8"	10	10	21.4	6	7	17	
JTASN-3/8-30-4	3/8"NPT-Φ4*30L	4	NPT 3/8"	30	10	21.4	6	7	17	
JTASN-3/8-30-2	3/8"NPT-Φ2*30L	2	NPT 3/8"	30	10	21.4	6	7	17	
JTASN-3/8-30-1	3/8"NPT-Φ1*30L	1	NPT 3/8"	30	10	21.4	6	7	17	
JTASN-3/8-50-4	3/8"NPT-Φ4*50L	4	NPT 3/8"	50	10	21.4	6	7	17	
JTASN-3/8-50-2	3/8"NPT-Φ2*50L	2	NPT 3/8"	50	10	21.4	6	7	17	
JTASN-3/8-50-1	3/8"NPT-Φ1*50L	1	NPT 3/8"	50	10	21.4	6	7	17	
JTASM-10-10-4	M10*1.25P-Φ4*10L	4	M10*1.25P	10	10	21.4	6	7	17	
JTASM-10-10-2	M10*1.25P-Φ2*10L	2	M10*1.25P	10	10	21.4	6	7	17	
JTASM-10-10-1	M10*1.25P-Φ1*10L	1	M10*1.25P	10	10	21.4	6	7	17	
JTASM-10-30-4	M10*1.25P-Φ4*30L	4	M10*1.25P	30	10	21.4	6	7	17	
JTASM-10-30-2	M10*1.25P-Φ2*30L	2	M10*1.25P	30	10	21.4	6	7	17	
JTASM-10-30-1	M10*1.25P-Φ1*30L	1	M10*1.25P	30	10	21.4	6	7	17	
JTASM-10-50-4	M10*1.25P-Φ4*50L	4	M10*1.25P	50	10	21.4	6	7	17	
JTASM-10-50-2	M10*1.25P-Φ2*50L	2	M10*1.25P	50	10	21.4	6	7	17	
JTASM-10-50-1	M10*1.25P-Φ1*50L	1	M10*1.25P	50	10	21.4	6	7	17	



### 鑲入式高壓萬向噴嘴

Mounted High Pressure Adjustable Nozzle

噴射方向與固定方向成一直線，固定方式以緊密配合鑲入，廣泛適用各種機械的噴水冷卻，噴氣等。

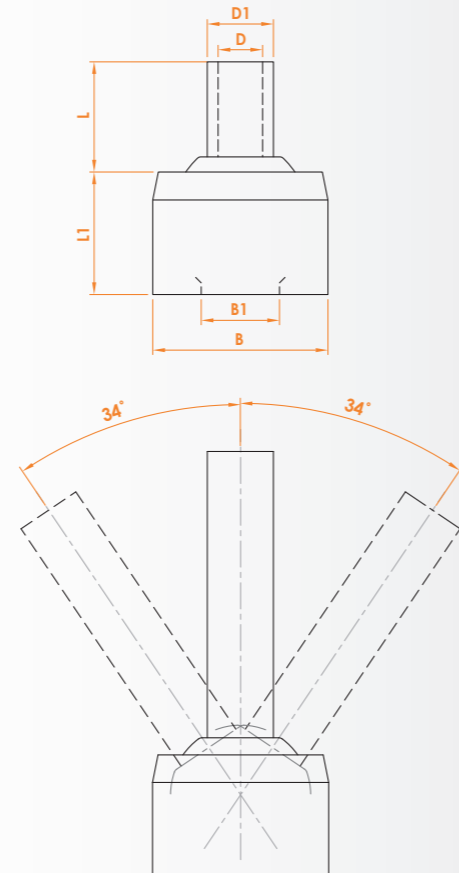
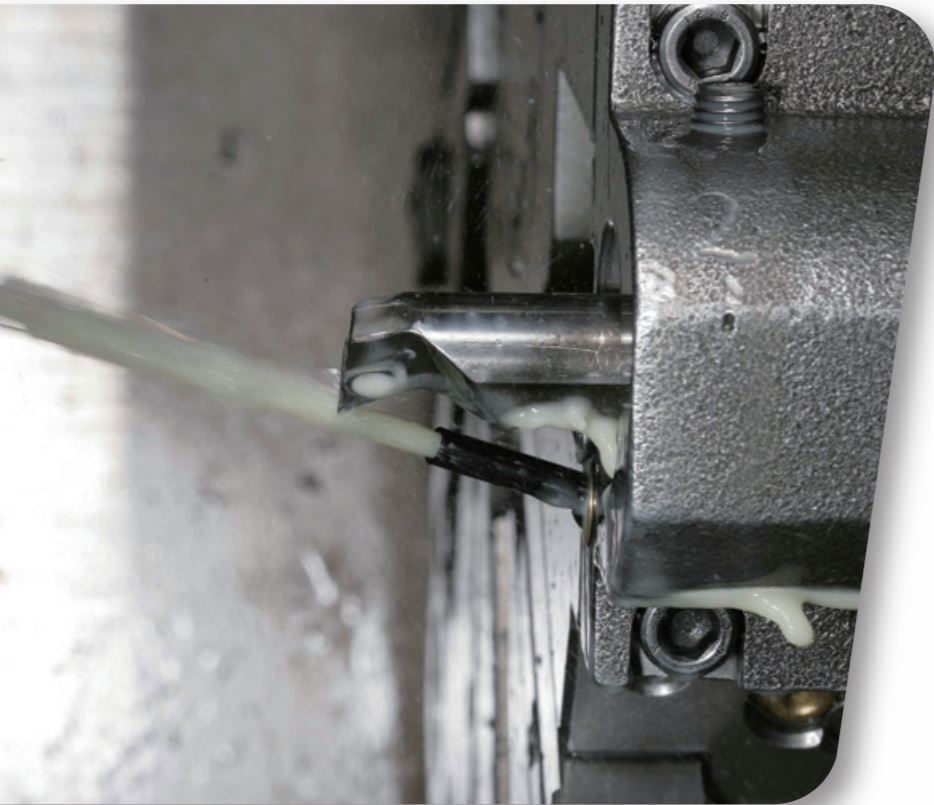

### 規格表

For Mounted High Pressure Adjustable Nozzle

● 可耐壓30kgf/cm<sup>2</sup>

型號	規格	主要尺寸						單位(mm)
		D	L	D1	L1	B1	Ø(B)	
JTDP-16-5-4	Φ16*Φ4*5L	4	5	6	11	7	16	
JTDP-16-5-2	Φ16*Φ2*5L	2	5	6	11	7	16	
JTDP-16-5-1	Φ16*Φ1*5L	1	5	6	11	7	16	
JTDP-16-10-4	Φ16*Φ4*10L	4	10	6	11	7	16	
JTDP-16-10-2	Φ16*Φ2*10L	2	10	6	11	7	16	
JTDP-16-10-1	Φ16*Φ1*10L	1	10	6	11	7	16	
JTDP-16-30-4	Φ16*Φ4*30L	4	30	6	11	7	16	
JTDP-16-30-2	Φ16*Φ2*30L	2	30	6	11	7	16	
JTDP-16-30-1	Φ16*Φ1*30L	1	30	6	11	7	16	
JTDP-16-50-4	Φ16*Φ4*50L	4	50	6	11	7	16	
JTDP-16-50-2	Φ16*Φ2*50L	2	50	6	11	7	16	
JTDP-16-50-1	Φ16*Φ1*50L	1	50	6	11	7	16	

型號	規格	主要尺寸						單位(mm)
		D	L	D1	L1	B1	Ø(B)	
JTDP-15-5-4	Φ15*Φ4*5L	4	5	6	8	7	15	
JTDP-15-5-2	Φ15*Φ2*5L	2	5	6	8	7	15	
JTDP-15-5-1	Φ15*Φ1*5L	1	5	6	8	7	15	
JTDP-15-10-4	Φ15*Φ4*10L	4	10	6	8	7	15	
JTDP-15-10-2	Φ15*Φ2*10L	2	10	6	8	7	15	
JTDP-15-10-1	Φ15*Φ1*10L	1	10	6	8	7	15	
JTDP-15-30-4	Φ15*Φ4*30L	4	30	6	8	7	15	
JTDP-15-30-2	Φ15*Φ2*30L	2	30	6	8	7	15	
JTDP-15-30-1	Φ15*Φ1*30L	1	30	6	8	7	15	
JTDP-15-50-4	Φ15*Φ4*50L	4	50	6	8	7	15	
JTDP-15-50-2	Φ15*Φ2*50L	2	50	6	8	7	15	
JTDP-15-50-1	Φ15*Φ1*50L	1	50	6	8	7	15	

型號	規格	主要尺寸						單位(mm)
		D	L	D1	L1	B1	Ø(B)	
JTDP-14-8-3	Φ14*Φ3*8L	3	8	5	8	7	14	

型號	規格	主要尺寸						單位(mm)
		D	L	D1	L1	B1	Ø(B)	
JTDP-12-5-2	Φ12*Φ2*5L	2	5	4	8	5.5	12	

型號	規格	主要尺寸						單位(mm)
		D	L	D1	L1	B1	Ø(B)	
JTDP-10-0-2	Φ10*Φ2	2	1	3	8	4.5	10	

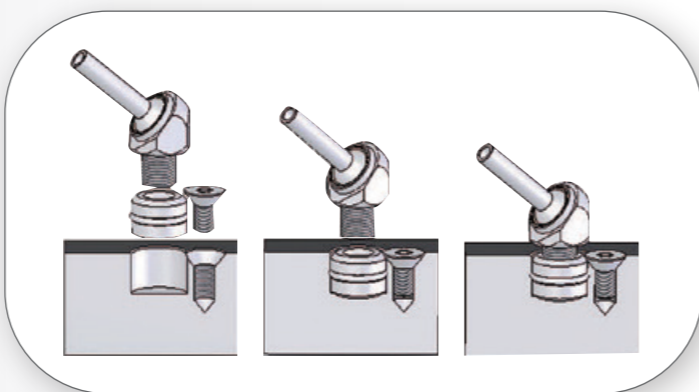
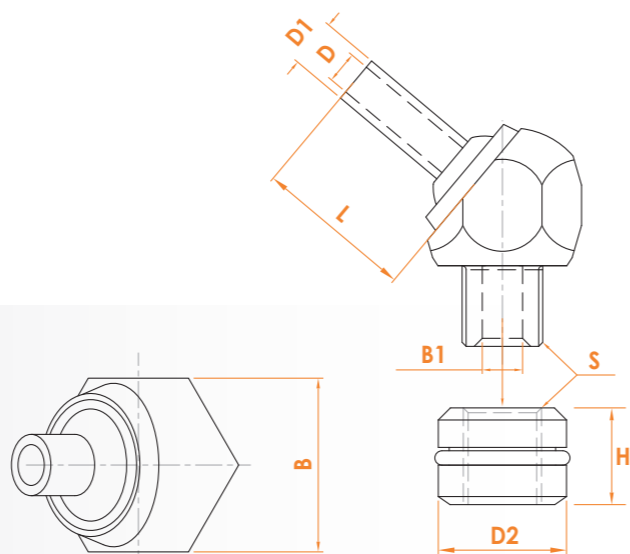

## 鑲入式斜噴高壓萬向噴嘴

Easy Jet-On High Pressure Adjustable Nozzle

噴射方向與固定方向成一夾角，固定方式為緊密配合鑲入，適用於各種工作母機。

- 調整角度容易。
- 定位精確穩固，不會反彈。
- 集中「水」力，準確噴射銑刀或鑽頭，確保加工過程中銑刀或鑽頭的充份冷卻，延長其使用壽命。
- 適用各種機械的噴水冷卻，噴氣。

### 高壓萬向噴嘴 可輕易調整噴射角度

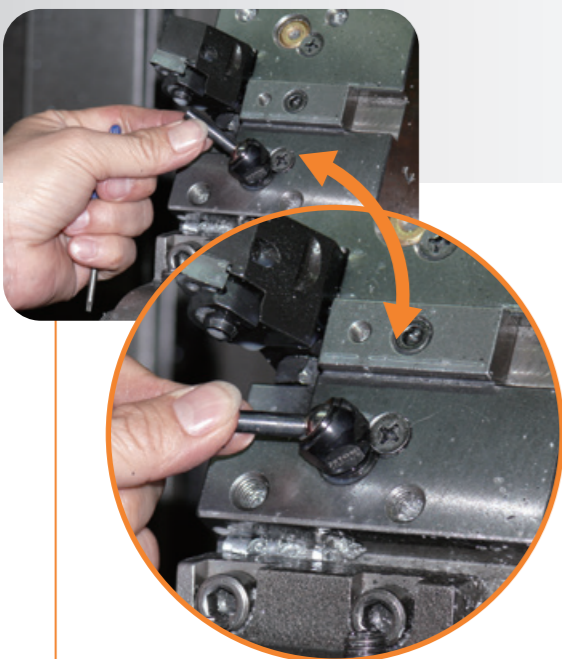

○ 可視工作需求，輕易的調整噴射角度、方向，節省寶貴的時間。

### 銅球型噴嘴 調整角度不易

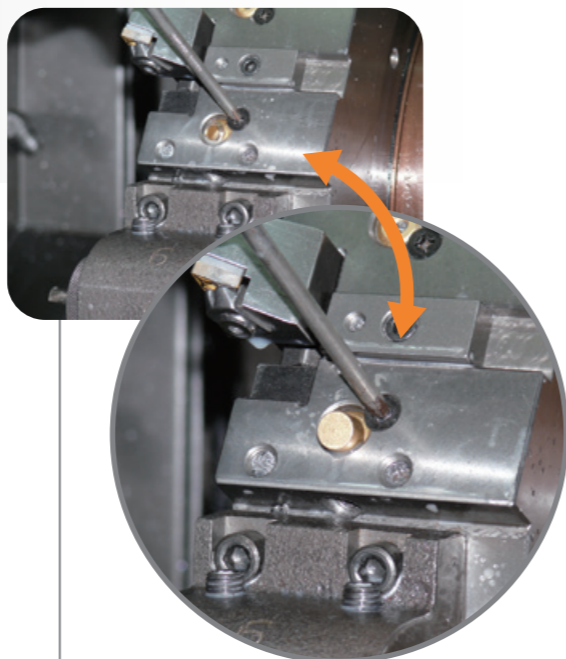

✗ 需使用工具才能調整角度，每次需耗費較多時間。

## 規格表

For Easy Jet-On High Pressure Adjustable Nozzle

● 可耐壓30kgf/cm<sup>2</sup>

型號	規格	主要尺寸							單位(mm)
		D2	D	螺紋(S)	L	D1	B1	H	六角面(B)
JTAT-10-M6-10-3	M6*1.0P-Φ3*10L	10	3	M6*1.0P	10	5	3	8.5	14
JTAT-10-M6-20-3	M6*1.0P-Φ3*20L	10	3	M6*1.0P	20	5	3	8.5	14
JTAT-12-M6-10-3	M6*1.0P-Φ3*10L	12	3	M6*1.0P	10	5	3	10.5	14
JTAT-12-M6-20-3	M6*1.0P-Φ3*20L	12	3	M6*1.0P	20	5	3	10.5	14

型號	規格	主要尺寸							單位(mm)
		D2	D	螺紋(S)	L	D1	B1	H	六角面(B)
JTAT-14-1/8-10-4	1/8"PT-Φ4*10L	14	4	PT 1/8"	10	6	6	10.5	17
JTAT-14-1/8-10-2	1/8"PT-Φ2*10L	14	2	PT 1/8"	10	6	6	10.5	17
JTAT-14-1/8-10-1	1/8"PT-Φ1*10L	14	1	PT 1/8"	10	6	6	10.5	17
JTAT-14-1/8-30-4	1/8"PT-Φ4*30L	14	4	PT 1/8"	30	6	6	10.5	17
JTAT-14-1/8-30-2	1/8"PT-Φ2*30L	14	2	PT 1/8"	30	6	6	10.5	17
JTAT-14-1/8-30-1	1/8"PT-Φ1*30L	14	1	PT 1/8"	30	6	6	10.5	17
JTAT-14-1/8-50-4	1/8"PT-Φ4*50L	14	4	PT 1/8"	50	6	6	10.5	17
JTAT-14-1/8-50-2	1/8"PT-Φ2*50L	14	2	PT 1/8"	50	6	6	10.5	17
JTAT-14-1/8-50-1	1/8"PT-Φ1*50L	14	1	PT 1/8"	50	6	6	10.5	17
JTAT-15-1/8-10-4	1/8"PT-Φ4*10L	15	4	PT 1/8"	10	6	6	10.5	17
JTAT-15-1/8-10-2	1/8"PT-Φ2*10L	15	2	PT 1/8"	10	6	6	10.5	17
JTAT-15-1/8-10-1	1/8"PT-Φ1*10L	15	1	PT 1/8"	10	6	6	10.5	17
JTAT-15-1/8-30-4	1/8"PT-Φ4*30L	15	4	PT 1/8"	30	6	6	10.5	17
JTAT-15-1/8-30-2	1/8"PT-Φ2*30L	15	2	PT 1/8"	30	6	6	10.5	17
JTAT-15-1/8-30-1	1/8"PT-Φ1*30L	15	1	PT 1/8"	30	6	6	10.5	17
JTAT-15-1/8-50-4	1/8"PT-Φ4*50L	15	4	PT 1/8"	50	6	6	10.5	17
JTAT-15-1/8-50-2	1/8"PT-Φ2*50L	15	2	PT 1/8"	50	6	6	10.5	17
JTAT-15-1/8-50-1	1/8"PT-Φ1*50L	15	1	PT 1/8"	50	6	6	10.5	17

型號	規格	主要尺寸							單位(mm)
		D2	D	螺紋(S)	L	D1	B1	H	六角面(B)
JTAT-16-1/8-10-4	1/8"PT-Φ4*10L	16	4	PT 1/8"	10	6	6	12	17
JTAT-16-1/8-10-2	1/8"PT-Φ2*10L	16	2	PT 1/8"	10	6	6	12	17
JTAT-16-1/8-10-1	1/8"PT-Φ1*10L	16	1	PT 1/8"	10	6	6	12	17
JTAT-16-1/8-30-4	1/8"PT-Φ4*30L	16	4	PT 1/8"	30	6	6	12	17
JTAT-16-1/8-30-2	1/8"PT-Φ2*30L	16	2	PT 1/8"	30	6	6	12	17
JTAT-16-1/8-30-1	1/8"PT-Φ1*30L	16	1	PT 1/8"	30	6	6	12	17
JTAT-16-1/8-50-4	1/8"PT-Φ4*50L	16	4	PT 1/8"	50	6	6	12	17
JTAT-16-1/8-50-2	1/8"PT-Φ2*50L	16	2	PT 1/8"	50	6	6	12	17
JTAT-16-1/8-50-1	1/8"PT-Φ1*50L	16	1	PT 1/8"	50	6	6	12	17
JTAT-18-1/8-10-4	1/8"PT-Φ4*10L	18	4	PT 1/8"	10	6	6	12	17
JTAT-18-1/8-10-2	1/8"PT-Φ2*10L	18	2	PT 1/8"	10	6	6	12	17
JTAT-18-1/8-10-1	1/8"PT-Φ1*10L	18	1	PT 1/8"	10	6	6	12	17
JTAT-18-1/8-30-4	1/8"PT-Φ4*30L	18	4	PT 1/8"	30	6	6	12	17
JTAT-18-1/8-30-2	1/8"PT-Φ2*30L	18	2	PT 1/8"	30	6	6	12	17
JTAT-18-1/8-30-1	1/8"PT-Φ1*30L	18	1	PT 1/8"	30	6	6	12	17
JTAT-18-1/8-50-4	1/8"PT-Φ4*50L	18	4	PT 1/8"	50	6	6	12	17
JTAT-18-1/8-50-2	1/8"PT-Φ2*50L	18	2	PT 1/8"	50	6	6	12	17
JTAT-18-1/8-50-1	1/8"PT-Φ1*50L	18	1	PT 1/8"	50	6	6	12	17

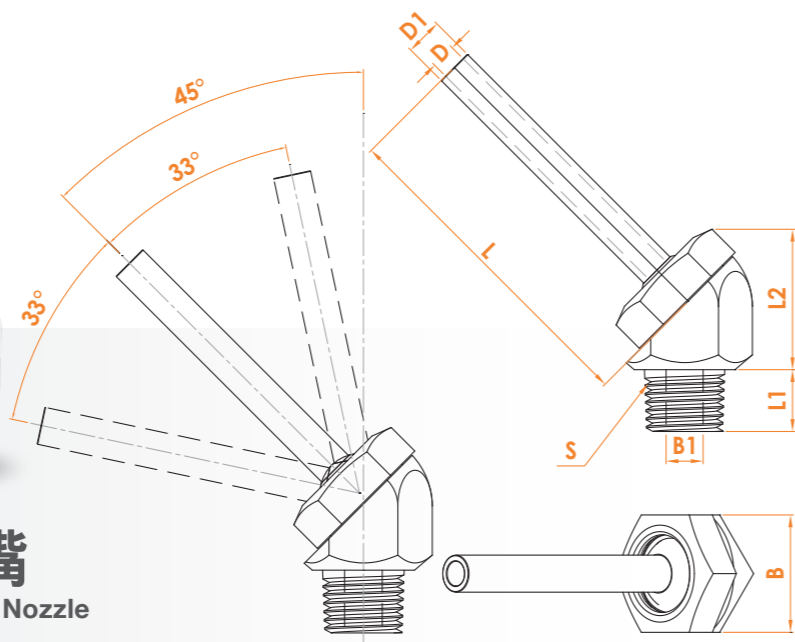

## 斜噴式-超高壓萬向噴嘴

Inclined-Injection Ultra High Pressure Adjustable Nozzle

超高壓噴嘴適用於水壓 100 公斤以內

型號	規格	主要尺寸								單位(mm)
		D	螺紋(S)	L	L1	L2	D1	B1	六角面(B)	
JTAP-1/8-10-4-H19	1/8"PT-Φ4*10L	4	PT 1/8"	10	10	23	6	6	19	
JTAP-1/8-10-2-H19	1/8"PT-Φ2*10L	2	PT 1/8"	10	10	23	6	6	19	
JTAP-1/8-10-1-H19	1/8"PT-Φ1*10L	1	PT 1/8"	10	10	23	6	6	19	
JTAP-1/8-30-4-H19	1/8"PT-Φ4*30L	4	PT 1/8"	30	10	23	6	6	19	
JTAP-1/8-30-2-H19	1/8"PT-Φ2*30L	2	PT 1/8"	30	10	23	6	6	19	
JTAP-1/8-30-1-H19	1/8"PT-Φ1*30L	1	PT 1/8"	30	10	23	6	6	19	
JTAP-1/8-50-4-H19	1/8"PT-Φ4*50L	4	PT 1/8"	50	10	23	6	6	19	
JTAP-1/8-50-2-H19	1/8"PT-Φ2*50L	2	PT 1/8"	50	10	23	6	6	19	
JTAP-1/8-50-1-H19	1/8"PT-Φ1*50L	1	PT 1/8"	50	10	23	6	6	19	
JTAP-1/4-10-4-H19	1/4"PT-Φ4*10L	4	PT 1/4"	10	10	23	6	6	19	
JTAP-1/4-10-2-H19	1/4"PT-Φ2*10L	2	PT 1/4"	10	10	23	6	6	19	
JTAP-1/4-10-1-H19	1/4"PT-Φ1*10L	1	PT 1/4"	10	10	23	6	6	19	
JTAP-1/4-30-4-H19	1/4"PT-Φ4*30L	4	PT 1/4"	30	10	23	6	6	19	
JTAP-1/4-30-2-H19	1/4"PT-Φ2*30L	2	PT 1/4"	30	10	23	6	6	19	
JTAP-1/4-30-1-H19	1/4"PT-Φ1*30L	1	PT 1/4"	30	10	23	6	6	19	
JTAP-1/4-50-4-H19	1/4"PT-Φ4*50L	4	PT 1/4"	50	10	23	6	6	19	
JTAP-1/4-50-2-H19	1/4"PT-Φ2*50L	2	PT 1/4"	50	10	23	6	6	19	
JTAP-1/4-50-1-H19	1/4"PT-Φ1*50L	1	PT 1/4"	50	10	23	6	6	19	
JTAN-1/8-10-4-H19	1/8"NPT-Φ4*10L	4	NPT 1/8"	10	10	23	6	6	19	
JTAN-1/8-10-2-H19	1/8"NPT-Φ2*10L	2	NPT 1/8"	10	10	23	6	6	19	
JTAN-1/8-10-1-H19	1/8"NPT-Φ1*10L	1	NPT 1/8"	10	10	23	6	6	19	
JTAN-1/8-30-4-H19	1/8"NPT-Φ4*30L	4	NPT 1/8"	30	10	23	6	6	19	
JTAN-1/8-30-2-H19	1/8"NPT-Φ2*30L	2	NPT 1/8"	30	10	23	6	6	19	
JTAN-1/8-30-1-H19	1/8"NPT-Φ1*30L	1	NPT 1/8"	30	10	23	6	6	19	
JTAN-1/8-50-4-H19	1/8"NPT-Φ4*50L	4	NPT 1/8"	50	10	23	6	6	19	
JTAN-1/8-50-2-H19	1/8"NPT-Φ2*50L	2	NPT 1/8"	50	10	23	6	6	19	
JTAN-1/8-50-1-H19	1/8"NPT-Φ1*50L	1	NPT 1/8"	50	10	23	6	6	19	
JTAN-1/4-10-4-H19	1/4"NPT-Φ4*10L	4	NPT 1/4"	10	10	23	6	6	19	
JTAN-1/4-10-2-H19	1/4"NPT-Φ2*10L	2	NPT 1/4"	10	10	23	6	6	19	
JTAN-1/4-10-1-H19	1/4"NPT-Φ1*10L	1	NPT 1/4"	10	10	23	6	6	19	
JTAN-1/4-30-4-H19	1/4"NPT-Φ4*30L	4	NPT 1/4"	30	10	23	6	6	19	
JTAN-1/4-30-2-H19	1/4"NPT-Φ2*30L	2	NPT 1/4"	30	10	23	6	6	19	
JTAN-1/4-30-1-H19	1/4"NPT-Φ1*30L	1	NPT 1/4"	30	10	23	6	6	19	
JTAN-1/4-50-4-H19	1/4"NPT-Φ4*50L	4	NPT 1/4"	50	10	23	6	6	19	
JTAN-1/4-50-2-H19	1/4"NPT-Φ2*50L	2	NPT 1/4"	50	10	23	6	6	19	
JTAN-1/4-50-1-H19	1/4"NPT-Φ1*50L	1	NPT 1/4"	50	10	23	6	6	19	
JTAM-10-10-4-H19	M10*1.25P-Φ4*10L	4	M10*1.25P	10	10	23	6	6	19	
JTAM-10-10-2-H19	M10*1.25P-Φ2*10L	2	M10*1.25P	10	10	23	6	6	19	
JTAM-10-10-1-H19	M10*1.25P-Φ1*10L	1	M10*1.25P	10	10	23	6	6	19	
JTAM-10-30-4-H19	M10*1.25P-Φ4*30L	4	M10*1.25P	30	10	23	6	6	19	
JTAM-10-30-2-H19	M10*1.25P-Φ2*30L	2	M10*1.25P	30	10	23	6	6	19	
JTAM-10-30-1-H19	M10*1.25P-Φ1*30L	1	M10*1.25P	30	10	23	6	6	19	
JTAM-10-50-4-H19	M10*1.25P-Φ4*50L	4	M10*1.25P	50	10	23	6	6	19	
JTAM-10-50-2-H19	M10*1.25P-Φ2*50L	2	M10*1.25P	50	10	23	6	6	19	
JTAM-10-50-1-H19	M10*1.25P-Φ1*50L	1	M10*1.25P	50	10	23	6	6	19	

### 規格表-斜噴式

For Inclined-Injection  
Ultra High Pressure  
Adjustable Nozzle

- 不鏽鋼材質
- 可耐壓100kg/cm<sup>2</sup>

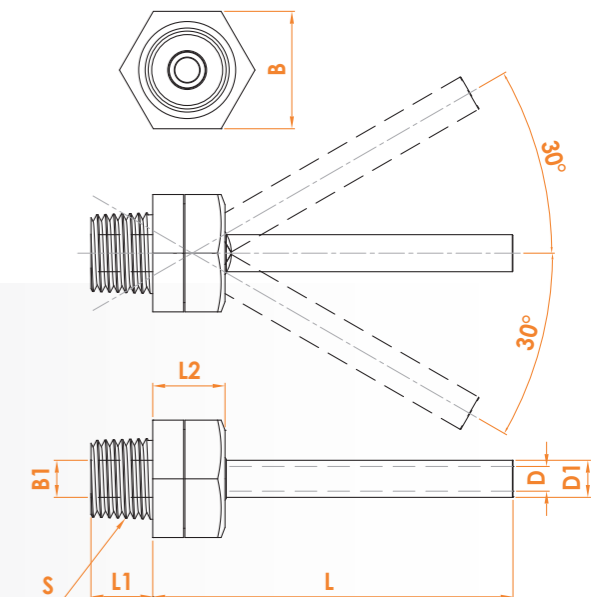

## 直噴式-超高壓萬向噴嘴

Direct-Injection Ultra High Pressure Adjustable Nozzle

超高壓噴嘴適用於水壓 100 公斤以內

型號	規格	主要尺寸								單位(mm)
		D	螺紋(S)	L	L1	L2	D1	B1	六角面(B)	
JTSP-1/8-20-4-H19	1/8"PT-Φ4*20L	4	PT 1/8"	20	10	12	6	6	19	
JTSP-1/8-20-2-H19	1/8"PT-Φ2*20L	2	PT 1/8"	20	10	12	6	6	19	
JTSP-1/8-20-1-H19	1/8"PT-Φ1*20L	1	PT 1/8"	20	10	12	6	6	19	
JTSP-1/8-40-4-H19	1/8"PT-Φ4*40L	4	PT 1/8"	40	10	12	6	6	19	
JTSP-1/8-40-2-H19	1/8"PT-Φ2*40L	2	PT 1/8"	40	10	12	6	6	19	
JTSP-1/8-40-1-H19	1/8"PT-Φ1*40L	1	PT 1/8"	40	10	12	6	6	19	
JTSP-1/8-60-4-H19	1/8"PT-Φ4*60L	4	PT 1/8"	60	10	12	6	6	19	
JTSP-1/8-60-2-H19	1/8"PT-Φ2*60L	2	PT 1/8"	60	10	12	6	6	19	
JTSP-1/8-60-1-H19	1/8"PT-Φ1*60L	1	PT 1/8"	60	10	12	6	6	19	
JTSP-1/4-20-4-H19	1/4"PT-Φ4*20L	4	PT 1/4"	20	10	12	6	6	19	
JTSP-1/4-20-2-H19	1/4"PT-Φ2*20L	2	PT 1/4"	20	10	12	6	6	19	
JTSP-1/4-20-1-H19	1/4"PT-Φ1*20L	1	PT 1/4"	20	10	12	6	6	19	
JTSP-1/4-40-4-H19	1/4"PT-Φ4*40L	4	PT 1/4"	40	10	12	6	6	19	
JTSP-1/4-40-2-H19	1/4"PT-Φ2*40L	2	PT 1/4"	40	10	12	6	6	19	
JTSP-1/4-40-1-H19	1/4"PT-Φ1*40L	1	PT 1/4"	40	10	12	6	6	19	
JTSP-1/4-60-4-H19	1/4"PT-Φ4*60L	4	PT 1/4"	60	10	12	6	6	19	
JTSP-1/4-60-2-H19	1/4"PT-Φ2*60L	2	PT 1/4"	60	10	12	6	6	19	
JTSP-1/4-60-1-H19	1/4"PT-Φ1*60L	1	PT 1/4"	60	10	12	6	6	19	
JTSN-1/8-20-4-H19	1/8"NPT-Φ4*20L	4	NPT 1/8"	20	10	12	6	6	19	
JTSN-1/8-20-2-H19	1/8"NPT-Φ2*20L	2	NPT 1/8"	20	10	12	6	6	19	
JTSN-1/8-20-1-H19	1/8"NPT-Φ1*20L	1	NPT 1/8"	20	10	12	6	6	19	
JTSN-1/8-40-4-H19	1/8"NPT-Φ4*40L	4	NPT 1/8"	40	10	12	6	6	19	
JTSN-1/8-40-2-H19	1/8"NPT-Φ2*40L	2	NPT 1/8"	40	10	12	6	6	19	
JTSN-1/8-40-1-H19	1/8"NPT-Φ1*40L	1	NPT 1/8"	40	10	12	6	6	19	
JTSN-1/8-60-4-H19	1/8"NPT-Φ4*60L	4	NPT 1/8"	60	10	12	6	6	19	
JTSN-1/8-60-2-H19	1/8"NPT-Φ2*60L	2	NPT 1/8"	60	10	12	6	6	19	
JTSN-1/8-60-1-H19	1/8"NPT-Φ1*60L	1	NPT 1/8"	60	10	12	6	6	19	
JTSN-1/4-20-4-H19	1/4"NPT-Φ4*20L	4	NPT 1/4"	20	10	12	6	6	19	
JTSN-1/4-20-2-H19	1/4"NPT-Φ2*20L	2	NPT 1/4"	20	10	12	6	6	19	
JTSN-1/4-20-1-H19	1/4"NPT-Φ1*20L	1	NPT 1/4"	20	10	12	6	6	19	
JTSN-1/4-40-4-H19	1/4"NPT-Φ4*40L	4	NPT 1/4"	40	10	12	6	6	19	
JTSN-1/4-40-2-H19	1/4"NPT-Φ2*40L	2	NPT 1/4"	40	10	12	6	6	19	
JTSN-1/4-40-1-H19	1/4"NPT-Φ1*40L	1	NPT 1/4"	40	10	12	6	6	19	
JTSN-1/4-60-4-H19	1/4"NPT-Φ4*60L	4	NPT 1/4"	60	10	12	6	6	19	
JTSN-1/4-60-2-H19	1/4"NPT-Φ2*60L	2	NPT 1/4"	60	10	12	6	6	19	
JTSN-1/4-60-1-H19	1/4"NPT-Φ1*60L	1	NPT 1/4"	60	10	12	6	6	19	
JTSM-10-20-4-H19	M10*1.25P*Φ4*20L	4	M10*1.25P	20	10	12	6	6	19	
JTSM-10-20-2-H19	M10*1.25P*Φ2*20L	2	M10*1.25P	20	10	12	6	6	19	
JTSM-10-20-1-H19	M10*1.25P*Φ1*20L	1	M10*1.25P	20	10	12	6	6	19	
JTSM-10-40-4-H19	M10*1.25P*Φ4*40L	4	M10*1.25P	40	10	12	6	6	19	
JTSM-10-40-2-H19	M10*1.25P*Φ2*40L	2	M10*1.25P	40	10	12	6	6	19	
JTSM-10-40-1-H19	M10*1.25P*Φ1*40L	1	M10*1.25P	40	10	12	6	6	19	
JTSM-10-60-4-H19	M10*1.25P*Φ4*60L	4	M10*1.25P	60	10	12	6	6	19	
JTSM-10-60-2-H19	M10*1.25P*Φ2*60L	2	M10*1.25P	60	10	12	6	6	19	
JTSM-10-60-1-H19	M10*1.25P*Φ1*60L	1	M10*1.25P	60	10	12	6	6	19	

### 規格表-直噴式

For Direct-Injection  
Ultra High Pressure  
Adjustable Nozzle

- 不鏽鋼材質
- 可耐壓100kg/cm<sup>2</sup>



## 應用範例

- 五支多面方向的冷卻噴射。
- 強力噴射冷卻，確保加工過程中充份的冷卻。
- 強力噴射冷卻，能夠把卡在鑽石輪上的屑渣沖洗掉，鑽石輪永保銳利，增長使用壽命。
- 強力噴射冷卻，更能將工作台上的屑渣沖洗掉，使工件清潔。

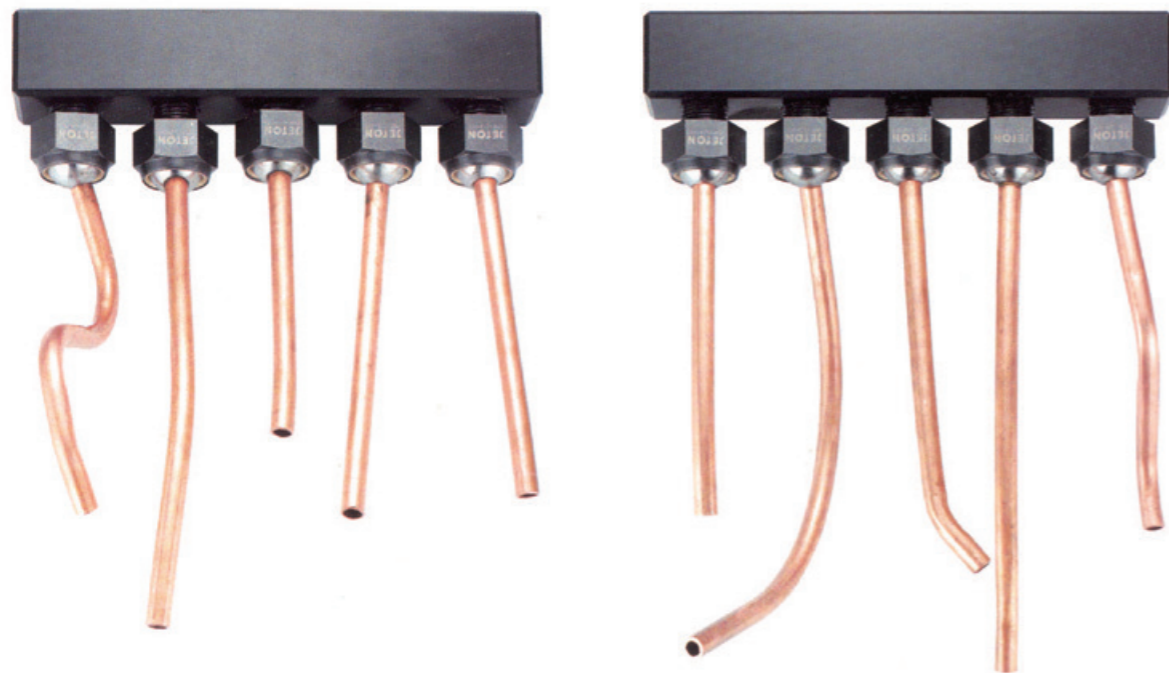

▲ 刀具研磨機使用範例

## 應用範例

- 五支多面方向的冷卻噴射。
- 強力噴射冷卻，確保加工過程中充份的冷卻。
- 強力噴射冷卻，能夠把卡在鑽石輪上的屑渣沖洗掉，使砂輪永保銳利，增長使用壽命。
- 強力噴射冷卻，更能將工作台上的屑渣沖洗掉，使工件清潔。



空壓機轉子研磨機 ▶

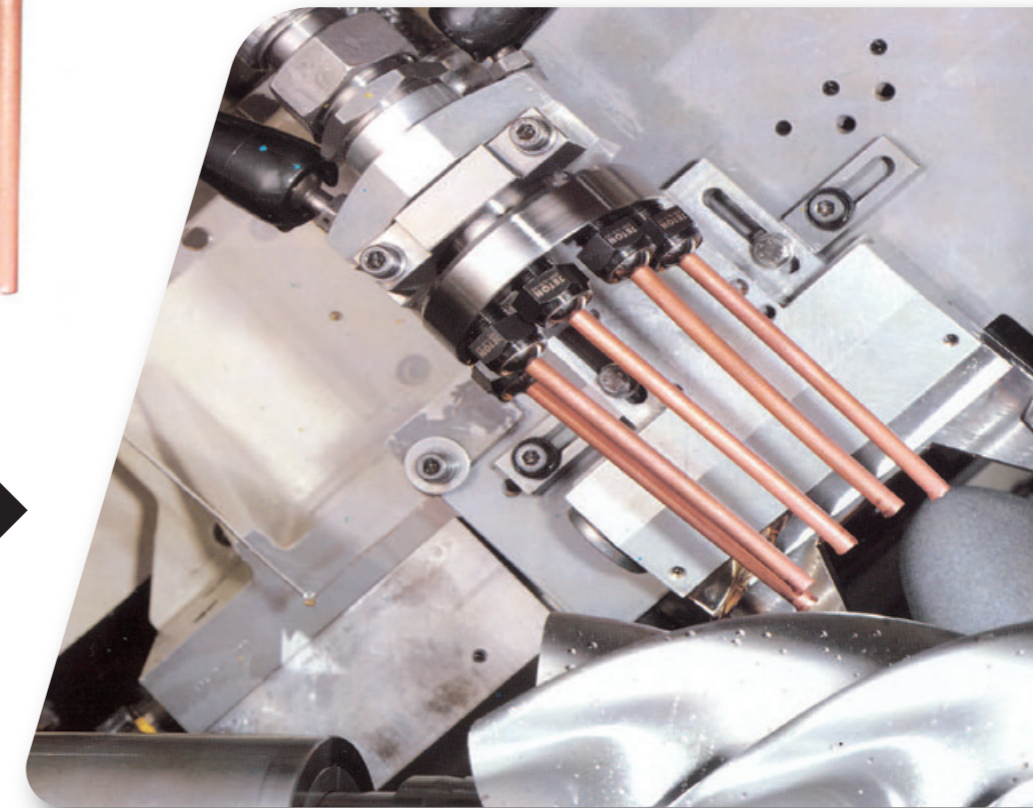



## JTF-001 噴霧裝置

鋁座	1 組
1/4" 萬向曲管	1 支
噴霧專用噴嘴	1 個

- 適用於高速之微量切削冷卻。
- 進口有二處，一為油、一為空氣。
- 調整螺栓可調節油、空氣輸出大小。
- 油與空氣皆為壓力輸出。

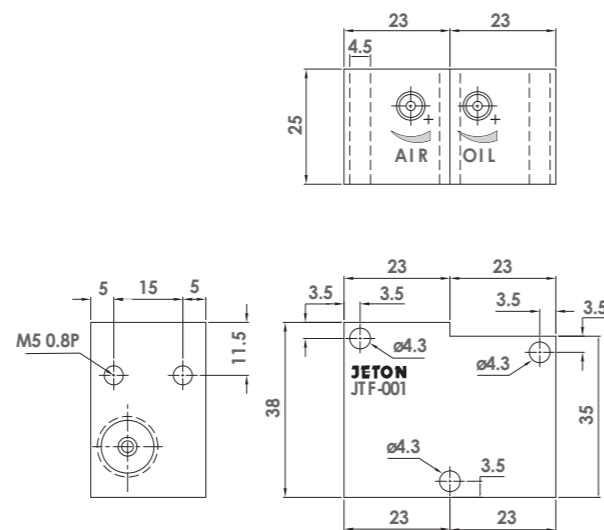

**建議使用壓力**  
氣壓：0.5~5 kgf/cm<sup>2</sup>  
液壓：0.5~2 kgf/cm<sup>2</sup>

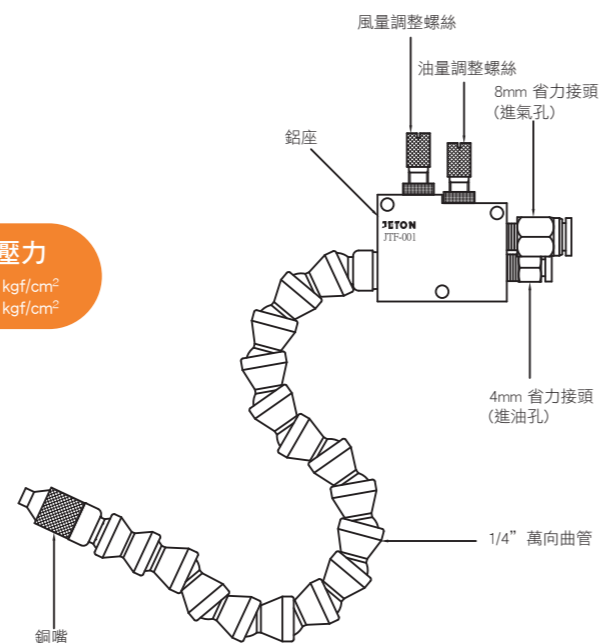

## JTF-002 噴霧裝置

鋁座	1 組
1/4" 萬向曲管	1 支
噴霧專用噴嘴	1 個

- 適用於高速之微量切削冷卻。
- 進口有二處，一為油、一為空氣。
- 調整螺栓可調節油、空氣輸出大小。
- 空氣為壓力輸出帶動油進入。

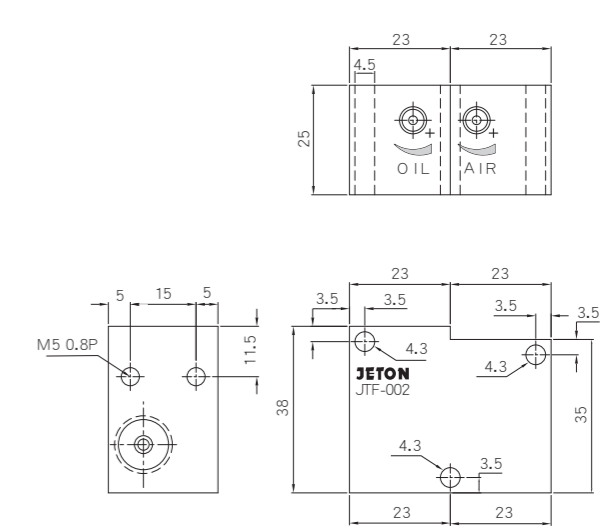

**建議使用壓力**  
氣壓：3.5~5 kgf/cm<sup>2</sup>  
液壓：0 kgf/cm<sup>2</sup>

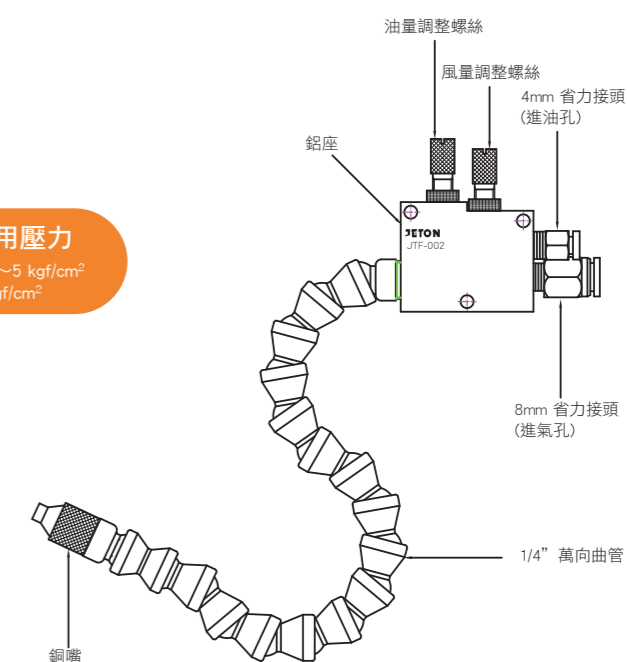

## JTF-001M 噴霧裝置磁座組

鋁座	1 組
1/4" 萬向曲管	1 支
噴霧專用噴嘴	1 個
磁性底座	1 組

**建議使用壓力**  
氣壓：0.5~5 kgf/cm<sup>2</sup>  
液壓：0.5~2 kgf/cm<sup>2</sup>

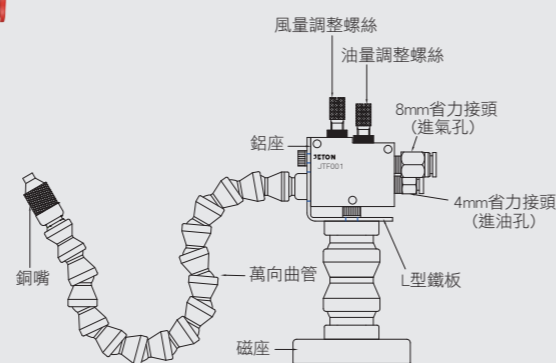

## JTF-002M 噴霧裝置磁座組

鋁座	1 組
1/4" 萬向曲管	1 支
噴霧專用噴嘴	1 個
磁性底座	1 組

**建議使用壓力**  
氣壓：3.5~5 kgf/cm<sup>2</sup>  
液壓：0 kgf/cm<sup>2</sup>

